



Dear customer,

Congratulations on choosing the Noctua NH-D15. Built on the basis of the legendary NH-D14 and carrying on its quest for ultimate quiet cooling performance, our flagship model NH-D15 is an eliteclass dual tower cooler for the highest demands. I'm confident that you will be able to sense some of the research, attention and care we've put into making this cooler.

Enjoy your NH-D15!

Yours sincerely,

*R. Müssig*  
Roland Müssig, Noctua CEO

This manual will guide you through the installation process of the SecuFirm2™ mounting system step by step.

Prior to installing the cooler, please consult the compatibility list on our website ([www.noctua.at/compatibility](http://www.noctua.at/compatibility)) and verify that the cooler is fully compatible with your motherboard.

Should you encounter any difficulties, please check the FAQs on our website ([www.noctua.at/faqs](http://www.noctua.at/faqs)) and don't hesitate to contact our support team at [support@noctua.at](mailto:support@noctua.at).

Noctua cannot be held responsible for any damage or losses caused by compatibility issues.

Multilingual versions of this manual are available on our website: [www.noctua.at/manuals](http://www.noctua.at/manuals)

**Required mounting parts:**

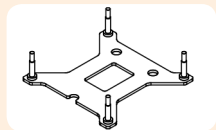

1x NM-IBP2 Backplate

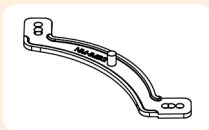

2x NM-IMB2 Mounting Bars

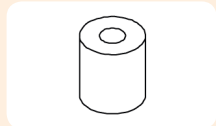

4x NM-IPS1 Spacers



4x NM-ITS1 Thumbscrews

**Step 1**

**Removing the mainboard**

In case you want to use the cooler on an assembled system and your case doesn't have a cut-out at the rear side of the mainboard tray, you first have to remove the mainboard from the case in order to be able to install the supplied backplate.

**Step 2**

**Attaching the backplate**

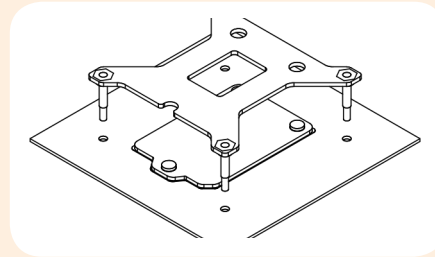

**Caution:** The supplied backplate will install over the mainboard's stock backplate, so the mainboard's stock backplate must not be taken off.

Place the backplate on the rear side of the mainboard so that the bolts stick through the mounting holes.

**Caution:** Please make sure that the three cut-outs in the supplied backplate align with the screws of the mainboard's stock backplate.

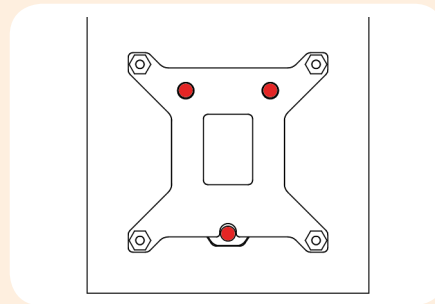

**Step 3**

**Installing the mounting bars**

First put the plastic spacers onto the bolts of the backplate, then add the mounting bars.

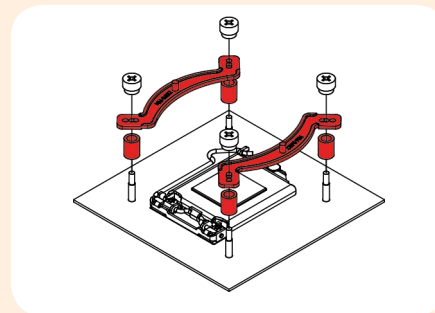

**Caution:** Choose the alignment of the mounting bars according to the desired final orientation of the cooler:

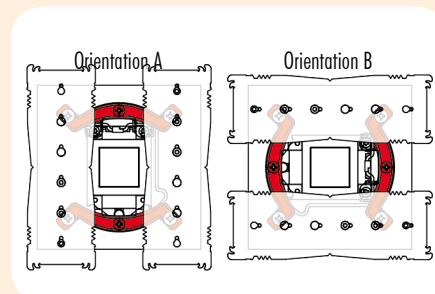

**Caution:** Make sure that the curved sides of the mounting bars are pointing outwards.

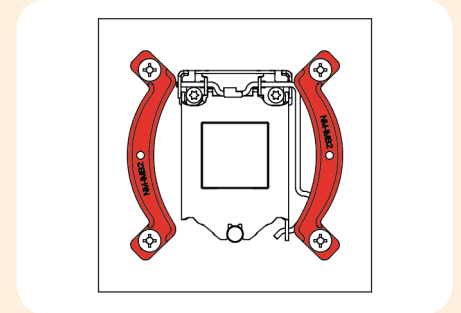

Fix the mounting bars using the 4 thumb screws.

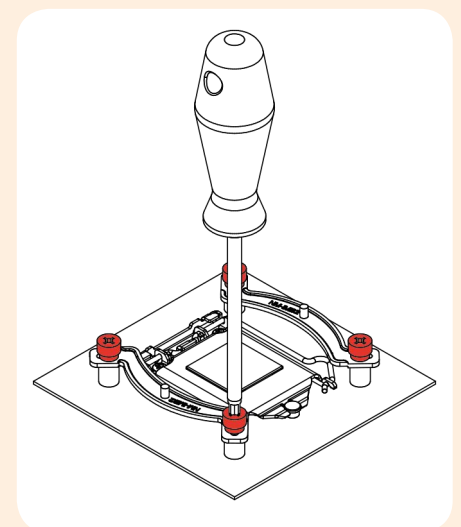

**Caution:** Gently tighten the screws until they stop, but don't use excessive force.

**Step 4**

**Applying thermal paste**

If there are residual traces of thermal paste or thermal pads on your CPU, please clean them off first. Then press a small drop (4-5mm diameter) of NT-H1 onto the centre of the heatspreader.

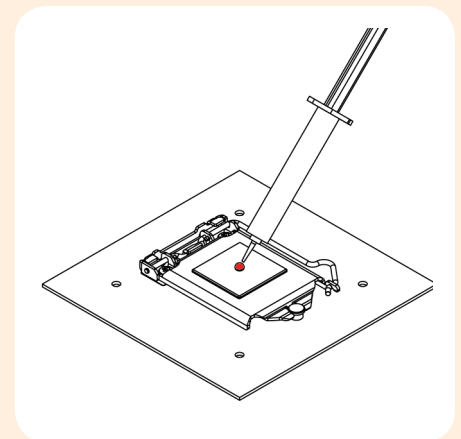

**Caution:** Applying too much thermal paste will lower heat conductivity and cooling performance!



Step 5

**Fastening the heatsink to the CPU**

**Caution:** Please first take off the center fan as well as the protection cover at the bottom side of the heatsink.

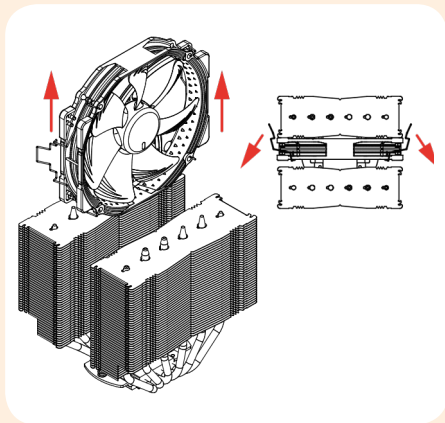

Then put the heatsink onto the CPU and screw it to the screw threads of the mounting bars.

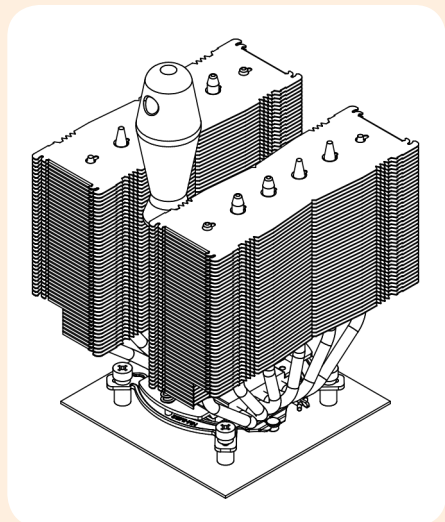

**Caution:** Tighten the screws until they stop.

Step 6

**Fan Setup**

Reattach the centre fan and, optionally, install the second fan (in grey) using the supplied steel clips:

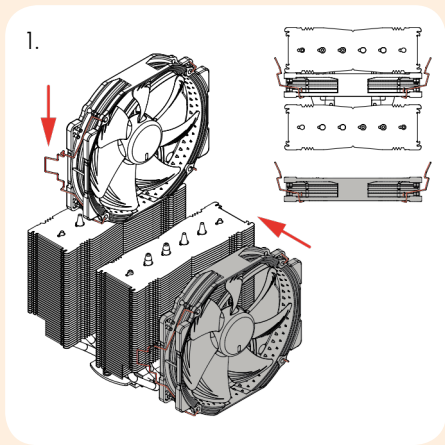

2.

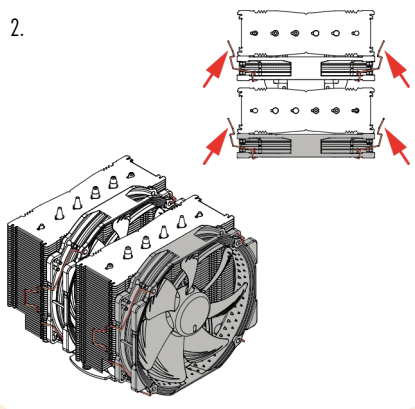

3.

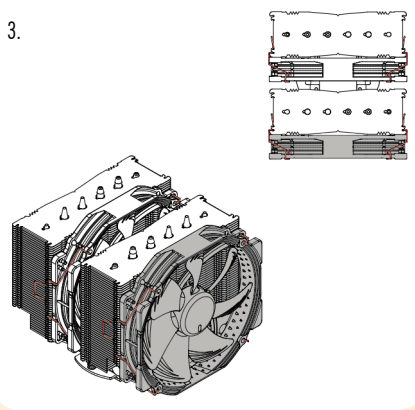

Use the heatsink with the centre fan only in order to guarantee best compatibility with tall RAM modules. Add the second fan to the front fin-stack for further improved cooling performance.

Connect the fan(s) to the mainboard's CPU fan header(s). If necessary, use the supplied NA-YC1 y-split cable to connect both fans to one fan header.

Depending on your CPU and the temperature inside the case, you may interconnect the supplied NA-RC7 Low-Noise Adaptors (L.N.A.) in order to further reduce the fans' operating noise.

**Caution:** Never use one adaptor for both fans by putting it before the y-split cable.

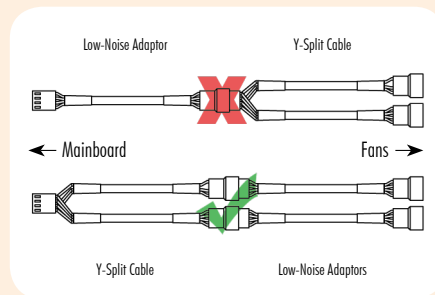

**Caution:** When using the L.N.A.s, check the temperature of your CPU using appropriate software (e.g. the respective applications of your mainboard manufacturer), in order to evade automatic throttling of the CPU due to the increased temperature. If the cooling performance is insufficient, please increase case ventilation or remove the L.N.A.s.

**Should I take the cooler off before transporting my system?**

As it is not possible to reliably calculate or control the forces that act upon a system during transport (e.g. in shipping), we generally recommend, for safety reasons, taking the cooler off. Noctua cannot be held responsible for any damage that may arise due to excessive stress during transport if you keep the heatsink installed.

**Warranty, Support and FAQs**

Even with high-grade products and strict quality control, the possibility of defects cannot be eliminated entirely. Therefore, we aim at providing the highest possible level of reliability and convenience by offering a warranty period of 6 years and direct, fast and straightforward RMA service.

Should you encounter any problems with your NH-D15, please don't hesitate to contact our support team ([support@noctua.at](mailto:support@noctua.at)).

Please also consult the FAQ section on our website: [www.noctua.at/faqs](http://www.noctua.at/faqs).



Dear customer,

Congratulations on choosing the Noctua NH-D15. Built on the basis of the legendary NH-D14 and carrying on its quest for ultimate quiet cooling performance, our flagship model NH-D15 is an eliteclass dual tower cooler for the highest demands. I'm confident that you will be able to sense some of the research, attention and care we've put into making this cooler.

Enjoy your NH-D15!

Yours sincerely,

*R. Müssig*  
Roland Mossig, Noctua CEO

This manual will guide you through the installation process of the SecuFirm2™ mounting system step by step.

Prior to installing the cooler, please consult the compatibility list on our website ([www.noctua.at/compatibility](http://www.noctua.at/compatibility)) and verify that the cooler is fully compatible with your motherboard.

Should you encounter any difficulties, please check the FAQs on our website ([www.noctua.at/faqs](http://www.noctua.at/faqs)) and don't hesitate to contact our support team at [support@noctua.at](mailto:support@noctua.at).

Noctua cannot be held responsible for any damage or losses caused by compatibility issues.

Multilingual versions of this manual are available on our website: [www.noctua.at/manuals](http://www.noctua.at/manuals)

**Required mounting parts:**

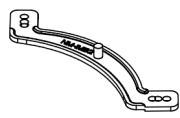

2x NM-IMB2 Mounting Bars

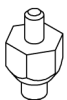

NM-IBT2 Bolts



4x NM-ITS1 Thumbscrews

**Step 1**

**Installing the mounting bars**

First screw the NM-IBT2 bolts into the screw threads of the LGA2011 socket frame.

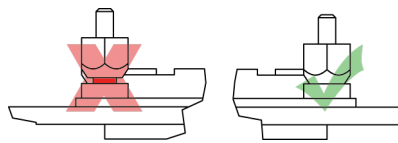
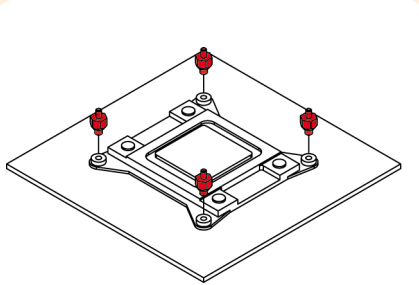

Then put the NM-IMB2 mounting-bars onto the bolts.

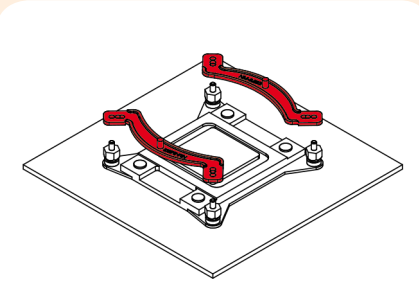

**Caution:** Choose the alignment of the mounting bars according to the desired final orientation of the cooler:

Orientation A

Orientation B

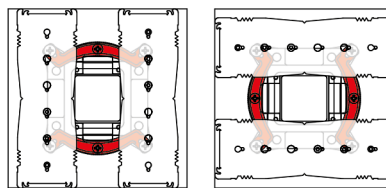

**Caution:** Make sure that the curved sides of the mounting bars are pointing outwards.

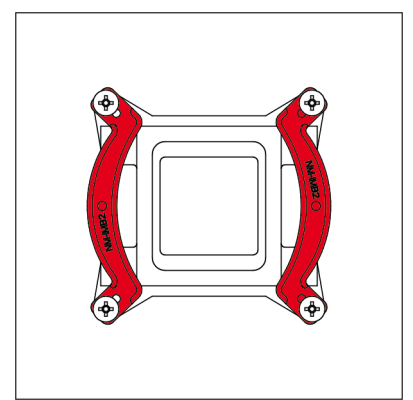

Fix the mounting bars using the 4 thumb screws.

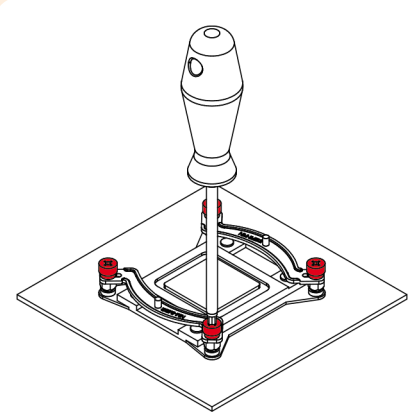

**Caution:** Gently tighten the screws until they stop, but don't use excessive force.

**Step 2**

**Applying thermal paste**

If there are residual traces of thermal paste or thermal pads on your CPU, please clean them off first. Then press a small drop (4-5mm diameter) of NT-H1 onto the centre of the heatspreader.

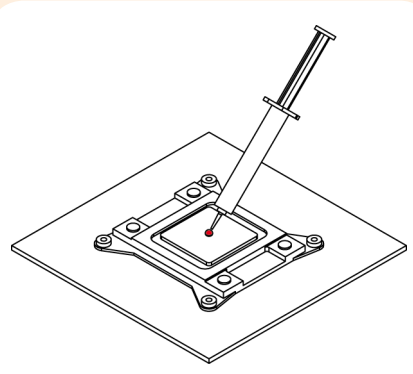

**Caution:** Applying too much thermal paste will lower the heat conductivity and cooling performance!



Step 3

**Fastening the heatsink to the CPU**

**Caution:** Please first take off the center fan as well as the protection cover at the bottom side of the heatsink.

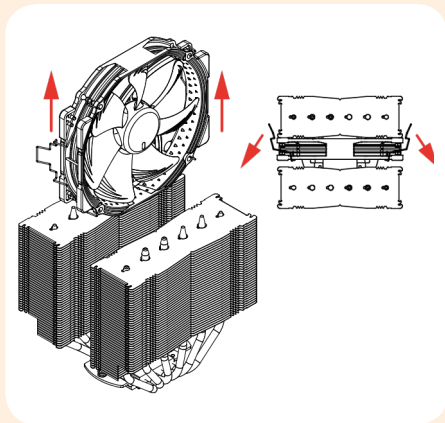

Then put the heatsink onto the CPU and screw it to the screw threads of the mounting bars.

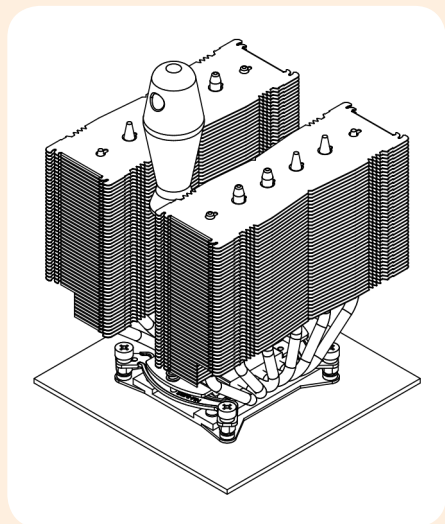

**Caution:** Tighten the screws until they stop.

Step 6

**Fan Setup**

Reattach the centre fan and, optionally, install the second fan (in grey) using the supplied steel clips:

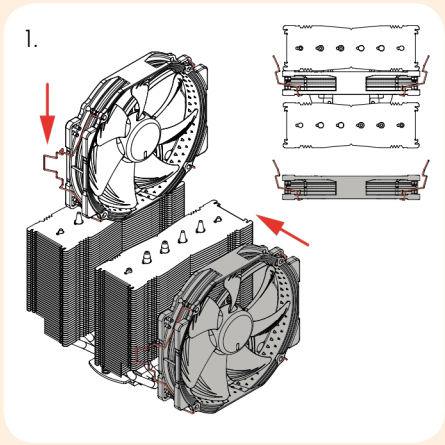

2.

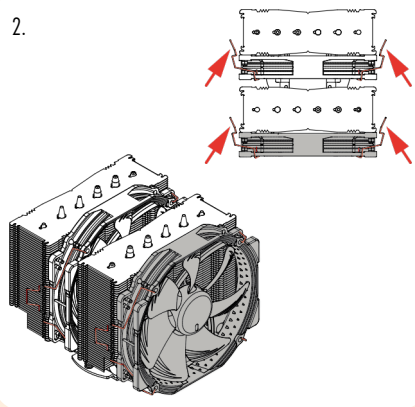

3.

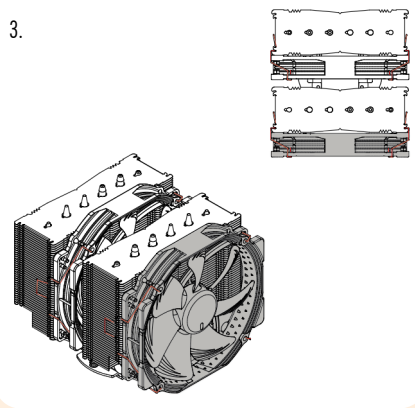

Use the heatsink with the centre fan only in order to guarantee best compatibility with tall RAM modules. Add the second fan to the front fin-stack for further improved cooling performance.

Connect the fan(s) to the mainboard's CPU fan header(s). If necessary, use the supplied NA-YC1 y-split cable to connect both fans to one fan header.

Depending on your CPU and the temperature inside the case, you may interconnect the supplied NA-RC7 Low-Noise Adaptors (L.N.A.) in order to further reduce the fans' operating noise.

**Caution:** Never use one adaptor for both fans by putting it before the y-split cable.

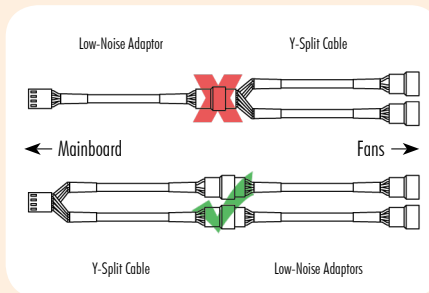

**Caution:** When using the L.N.A.s, check the temperature of your CPU using appropriate software (e.g. the respective applications of your mainboard manufacturer), in order to evade automatic throttling of the CPU due to the increased temperature. If the cooling performance is insufficient, please increase case ventilation or remove the L.N.A.s.

**Should I take the cooler off before transporting my system?**

As it is not possible to reliably calculate or control the forces that act upon a system during transport (e.g. in shipping), we generally recommend, for safety reasons, taking the cooler off. Noctua cannot be held responsible for any damage that may arise due to excessive stress during transport if you keep the heatsink installed.

**Warranty, Support and FAQs**

Even with high-grade products and strict quality control, the possibility of defects cannot be eliminated entirely. Therefore, we aim at providing the highest possible level of reliability and convenience by offering a warranty period of 6 years and direct, fast and straightforward RMA service.

Should you encounter any problems with your NH-D15, please don't hesitate to contact our support team ([support@noctua.at](mailto:support@noctua.at)).

Please also consult the FAQ section on our website: [www.noctua.at/faqs](http://www.noctua.at/faqs).



Dear customer,

Congratulations on choosing the Noctua NH-D15. Built on the basis of the legendary NH-D14 and carrying on its quest for ultimate quiet cooling performance, our flagship model NH-D15 is an eliteclass dual tower cooler for the highest demands. I'm confident that you will be able to sense some of the research, attention and care we've put into making this cooler.

Enjoy your NH-D15!

Yours sincerely,

*R. Müssig*  
Roland Müssig, Noctua CEO

**Caution:** The SecuFirm2™ mounting system requires a backplate, which is preinstalled on most AMD mainboards. If your mainboard doesn't have a backplate, please contact our support team at [support@noctua.at](mailto:support@noctua.at).

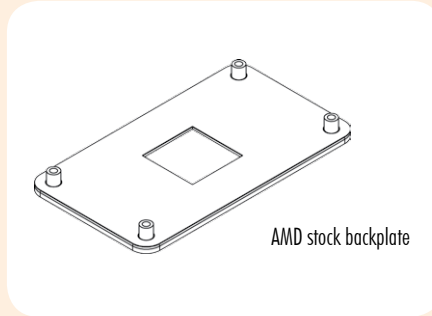

**Caution:** Make sure that the curved sides of the mounting bars are pointing outwards.

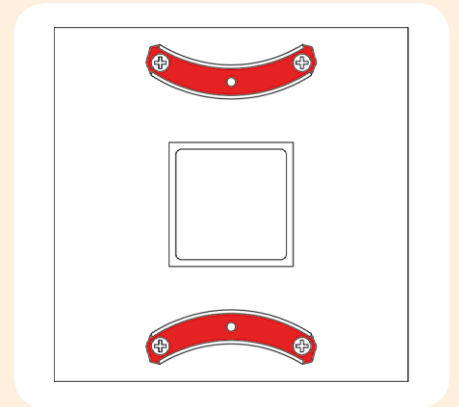

This manual will guide you through the installation process of the SecuFirm2™ mounting system step by step.

Prior to installing the cooler, please consult the compatibility list on our website ([www.noctua.at/compatibility](http://www.noctua.at/compatibility)) and verify that the cooler is fully compatible with your motherboard.

Should you encounter any difficulties, please check the FAQs on our website ([www.noctua.at/faqs](http://www.noctua.at/faqs)) and don't hesitate to contact our support team at [support@noctua.at](mailto:support@noctua.at).

Noctua cannot be held responsible for any damage or losses caused by compatibility issues.

Multilingual versions of this manual are available on our website: [www.noctua.at/manuals](http://www.noctua.at/manuals)

**Step 1**

**Removing the retention module**

If your mainboard uses a retention module for CPU cooler installation, please remove it first. The SecuFirm2™ mounting system will install directly to your mainboard's stock backplate on the rear side of the socket.

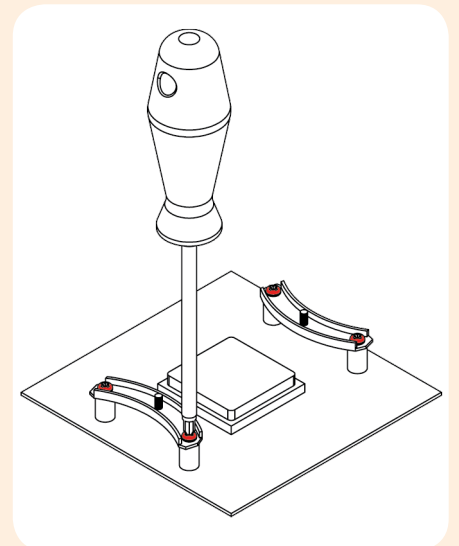

**Caution:** Tighten the screws until they stop.

**Step 2**

**Attaching the mounting bars**

First put the plastic spacers onto the screw threads, then fix the mounting bars using the 4 long screws.

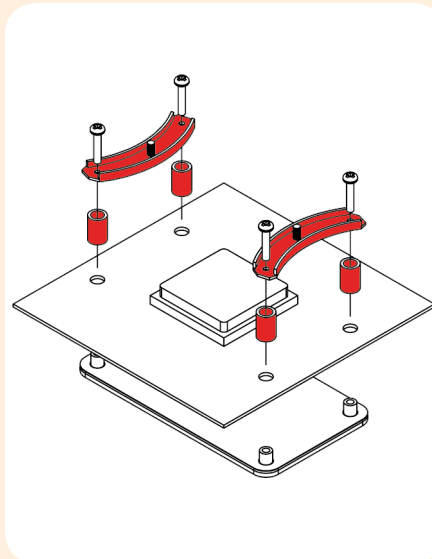

**Step 2**

**Applying thermal paste**

If there are residual traces of thermal paste or thermal pads on your CPU, please clean them off first. Then press a small drop (4-5mm diameter) of NT-H1 onto the centre of the heatspreader.

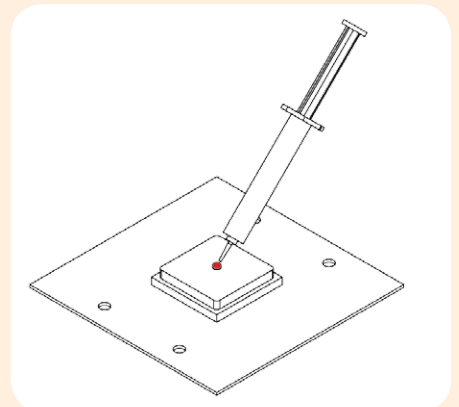

**Caution:** Applying too much thermal paste will lower the heat conductivity and cooling performance!

**Required mounting parts:**

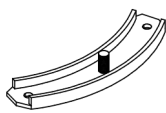

2x NM-AMB1 Mounting Bars

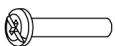

4x NM-ALS1 Screws



4x NM-APS1 Plastic Spacers



Step 4

**Fastening the heatsink to the CPU**

**Caution:** Please first take off the center fan as well as the protection cover at the bottom side of the heatsink.

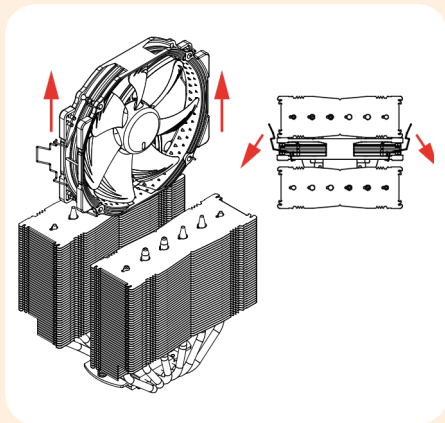

Then put the heatsink onto the CPU and screw it to the screw threads of the mounting bars.

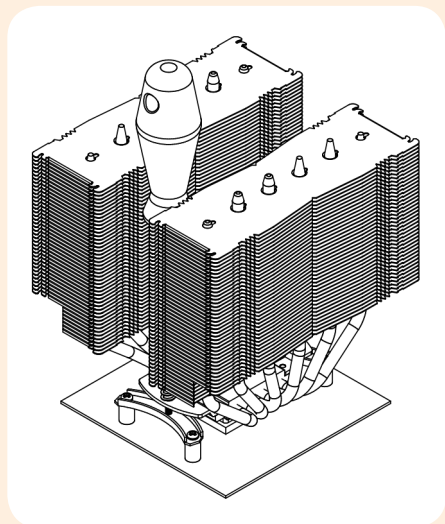

**Caution:** Tighten the screws until they stop.

Step 5

**Fan Setup**

Reattach the centre fan and, optionally, install the second fan (in grey) using the supplied steel clips:

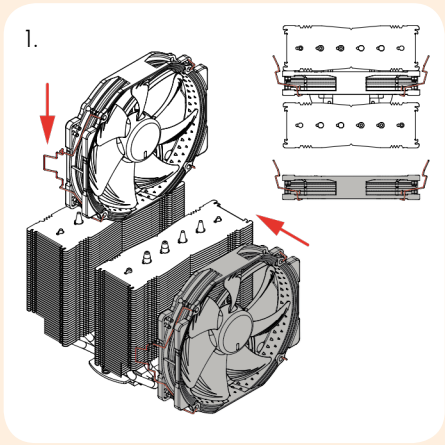

2.

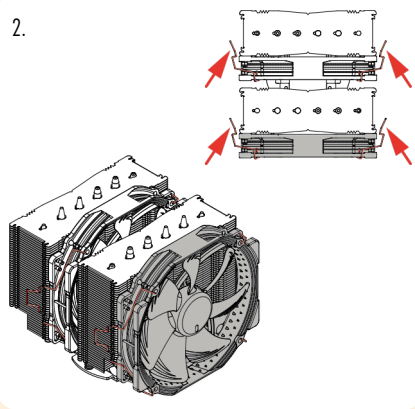

3.

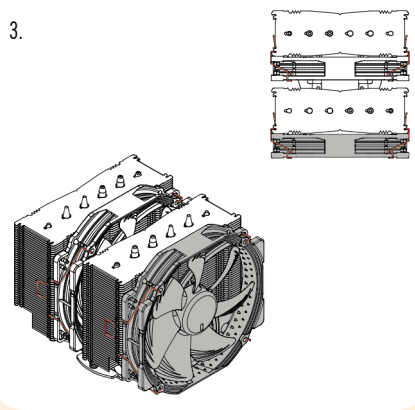

Use the heatsink with the centre fan only in order to guarantee best compatibility with tall RAM modules. Add the second fan to the front fin-stack for further improved cooling performance.

Connect the fan(s) to the mainboard's CPU fan header(s). If necessary, use the supplied NA-YC1 y-split cable to connect both fans to one fan header.

Depending on your CPU and the temperature inside the case, you may interconnect the supplied NA-RC7 Low-Noise Adaptors (L.N.A.) in order to further reduce the fans' operating noise.

**Caution:** Never use one adaptor for both fans by putting it before the y-split cable.

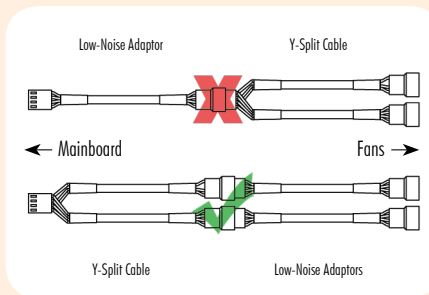

**Caution:** When using the L.N.A.s, check the temperature of your CPU using appropriate software (e.g. the respective applications of your mainboard manufacturer), in order to evade automatic throttling of the CPU due to the increased temperature. If the cooling performance is insufficient, please increase case ventilation or remove the L.N.A.s.

**Should I take the cooler off before transporting my system?**

As it is not possible to reliably calculate or control the forces that act upon a system during transport (e.g. in shipping), we generally recommend, for safety reasons, taking the cooler off. Noctua cannot be held responsible for any damage that may arise due to excessive stress during transport if you keep the heatsink installed.

**Warranty, Support and FAQs**

Even with high-grade products and strict quality control, the possibility of defects cannot be eliminated entirely. Therefore, we aim at providing the highest possible level of reliability and convenience by offering a warranty period of 6 years and direct, fast and straightforward RMA service.

Should you encounter any problems with your NH-D15, please don't hesitate to contact our support team ([support@noctua.at](mailto:support@noctua.at)).

Please also consult the FAQ section on our website: [www.noctua.at/faqs](http://www.noctua.at/faqs).