

SmartNode 5570

Enterprise Session Border Router

User Manual



This is a Class A device and is not intended for use in a residential environment.

Sales Office: +1 (301) 975-1000
Technical Support: +1 (301) 975-1007
E-mail: support@patton.com
WWW: www.patton.com

Patton Electronics Company, Inc.

7622 Rickenbacker Drive
Gaithersburg, MD 20879 USA
tel: +1 (301) 975-1000
fax: +1 (301) 869-9293
support: +1 (301) 975-1007
web: www.patton.com
e-mail: support@patton.com

Trademark Statement

The term *SmartNode* is trademarks of Patton Electronics Company. All other trademarks presented in this document are the property of their respective owners.

Copyright © 2015, Patton Electronics Company. All rights reserved.

The information in this document is subject to change without notice. Patton Electronics assumes no liability for errors that may appear in this document.

Warranty Information

The software described in this document is furnished under a license and may be used or copied only in accordance with the terms of such license.

Patton Electronics warrants all SmartNode extender components to be free from defects, and will—at our option—repair or replace the product should it fail within one year from the first date of the shipment.

This warranty is limited to defects in workmanship or materials, and does not cover customer damage, abuse or unauthorized modification. If the product fails to perform as warranted, your sole recourse shall be repair or replacement as described above. Under no condition shall **Patton Electronics** be liable for any damages incurred by the use of this product. These damages include, but are not limited to, the following: lost profits, lost savings and incidental or consequential damages arising from the use of or inability to use this product. **Patton Electronics** specifically disclaims all other warranties, expressed or implied, and the installation or use of this product shall be deemed an acceptance of these terms by the user.

Summary Table of Contents

- 1 General Information 14
- 2 Applications Overview 19
- 3 SmartNode Installation 22
- 4 Initial Configuration 27
- 5 Contacting Patton for Assistance 32
- A Compliance Information 35
- B Specifications 38
- C Cabling 42
- D Port pin-outs 47
- E SmartNode 5570 Factory Configuration 50
- F End User License Agreement 52

Table of Contents

Summary Table of Contents	3
Table of Contents	4
List of Figures	7
List of Tables	8
About this guide	9
Safety when working with electricity	11
Preventing electrostatic discharge damage	12
General observations	12
General conventions	13
1 General Information	14
SmartNode 5570 Overview	15
SmartNode 5570 Rear Panel	16
SmartNode 5570 Front Panel	18
2 Applications Overview	19
Introduction	20
Application—Edge Intelligence of Enterprise Communication	20
Application—Multi-service ISDN, Secure VoIP and Data Routing Solution	21
3 SmartNode Installation	22
Planning the Installation	23
Site log	23
Network information	23
Network Diagram	23
IP related information	23
Software tools	24
Power source	24
Location and mounting requirements	24
Installing the Patton SmartNode ESBR	24
Placing the SmartNode	24
Installing cables	24
4 Initial Configuration	27
Introduction	28
Connecting the SmartNode to Your Laptop PC	28
Configure the Desired IP Address	29
Factory-default IP Settings	29
Login	29
Changing the WAN IP address	29
Connecting the SmartNode to the Network	30
Loading the Configuration (optional)	31
Additional Information	31

5	Contacting Patton for Assistance	32
	Introduction	33
	Contact information	33
	Contacting Patton Technical Services for Free Support	33
	Warranty Service and Returned Merchandise Authorizations (RMAs)	33
	Warranty coverage	33
	RMA numbers	34
A	Compliance Information	35
	Compliance	36
	EMC	36
	Safety	36
	Radio and TV interference	36
	CE Declaration of Conformity	36
	Authorized European Representative	36
	ISDN Compliance	37
B	Specifications	38
	DSP	39
	Voice Connectivity	39
	Data Connectivity	39
	Voice Processing (signalling dependent)	39
	Fax and modem support	40
	Voice Signalling	40
	Voice Routing—session router	40
	IP Services	41
	Management	41
	System	41
	Physical	41
C	Cabling	42
	Introduction	43
	Serial Console	43
	Ethernet	44
	ISDN PRI (E1/T1)	45
D	Port pin-outs	47
	Introduction	48
	Console port	48
	Ethernet	48
	ISDN PRI (E1/T1) Port Pin-outs	49
E	SmartNode 5570 Factory Configuration	50
	Introduction	51
F	End User License Agreement	52
	End User License Agreement	53
	1. Definitions	53

2. Title53
3. Term53
4. Grant of License53
5. Warranty53
6. Termination54
7. Other Licenses54

List of Figures

1	SmartNode 5570 (Front)	15
2	SN5570 Rear Panel	16
3	SmartNode 5570 front panel	18
4	Edge intelligence of enterprise communication application	20
5	Multi-service ISDN, Secure VoIP and Data Routing Solution	21
6	Power LED	26
7	Connecting the SmartNode to your Laptop PC	28
8	Connecting the SmartNode to the network	30
9	Connecting a serial terminal	43
10	Typical Ethernet straight-through cable diagram for 10/100Base-T	44
11	Typical Ethernet straight-through cable diagram for 1000Base-T	44
12	PRI E1/T1 Cabling	46
13	PRI E1/T1 cross-over cable	46
14	EIA-561 (RJ-45 8-pin) port	48

List of Tables

1	General conventions	13
2	Rear panel ports	16
3	Rear Panel Ports (Continued)	17
4	SmartNode 5570 LED Definitions	18
5	Sample site log entries	23
6	Factory Default IP Address and Network Mask Configuration	29
7	10/100 Base-T RJ-45 socket	48
8	1000Base-T RJ-45 Socket	49
9	Port 0/0	49
10	Port 0/1	49

About this guide

This guide describes the SmartNode 5570 hardware, installation and basic configuration. For detailed software configuration information refer to the *Trinity Release 3.5.x- Command Line Reference Guide* and the available *Knowledgebase*.

Audience

This guide is intended for the following users:

- Operators
- Installers
- Maintenance technicians

Structure

This guide contains the following chapters and appendices:

- [Chapter 1](#) on page 14 provides information about router features and capabilities
- [Chapter 2](#) on page 19 contains an overview describing router operation and applications
- [Chapter 3](#) on page 22 provides quick start hardware installation procedures
- [Chapter 4](#) on page 27 provides quick-start procedures for configuring the SmartNode router
- [Chapter 5](#) on page 32 contains information on contacting Patton technical support for assistance
- [Appendix A](#) on page 35 contains compliance and regulatory information for the router
- [Appendix B](#) on page 38 contains specifications for the routers
- [Appendix C](#) on page 42 provides cable recommendations
- [Appendix D](#) on page 47 describes the ESBR's ports and pin-outs
- [Appendix E](#) on page 50 lists the factory configuration settings for SmartNode 5570
- [Appendix F](#) on page 52 provides license information that describes acceptable usage of the software provided with the SmartNode 5570

For best results, read the contents of this guide *before* you install the ESBR.

Precautions

Notes, cautions, and warnings, which have the following meanings, are used throughout this guide to help you become aware of potential ESBR problems. *Warnings* are intended to prevent safety hazards that could result in personal injury. *Cautions* refer to potential property damage or impaired functioning.

Note Calls attention to important information.



The shock hazard symbol and WARNING heading indicate a potential electric shock hazard. Strictly follow the warning instructions to avoid injury caused by electric shock.



The alert symbol and WARNING heading indicate a potential safety hazard. Strictly follow the warning instructions to avoid personal injury.



The shock hazard symbol and CAUTION heading indicate a potential electric shock hazard. Strictly follow the instructions to avoid property damage caused by electric shock.



The alert symbol and CAUTION heading indicate a potential hazard. Strictly follow the instructions to avoid property damage.

Safety when working with electricity



- This device contains no user serviceable parts. The device can only be repaired by qualified service personnel.
- Do not open the device when the power cord is connected. For systems without a power switch, and without an external power adapter, line voltages are present within the device when the power cord is connected.
- For devices with an external power adapter, the power adapter shall be a listed *Limited Power Source*. The mains outlet that is utilized to power the device shall be within 10 feet (3 meters) of the device, shall be easily accessible, and protected by a circuit breaker in compliance with local regulatory requirements.
- For AC powered devices, ensure that the power cable used meets all applicable standards for the country in which it is to be installed.
- For AC powered devices which have 3 conductor power plugs (L1, L2 & GND or Hot, Neutral & Safety/Protective Ground), the wall outlet (or socket) must have an earth ground.
- For DC powered devices, ensure that the interconnecting cables are rated for proper voltage, current, anticipated temperature, flammability, and mechanical serviceability.
- WAN, LAN & PSTN ports (connections) may have hazardous network voltages are present, regardless of whether the device is powered ON or OFF. PSTN relates to interfaces such as telephone lines. FXS, FXO, DSL, xDSL, T1, E1, ISDN, Voice, etc. These are known as “hazardous network voltages” and to avoid electric shock use caution when working near these ports. When disconnecting cables for these ports, detach the far end connection of the SmartNode first.
- Do not work on the device or connect or disconnect cables during periods of lightning activity.
- If one has reason to open the chassis or case, then the precautions mentioned above shall be followed. This includes both the warnings relating to disconnection of the input power, and the warnings relating to the disconnection of WAN, LAN & PSTN ports.



In accordance with the requirements of council directive 2002/96/EC on Waste of Electrical and Electronic Equipment (WEEE), ensure that at end-of-life you separate this product from other waste and scrap and deliver to the WEEE collection system in your country for recycling.

Preventing electrostatic discharge damage

When starting to install interface cards place the interface card on its shielded plastic bag if you lay it on your bench.



CAUTION

Electrostatic Discharge (ESD) can damage equipment and impair electrical circuitry. It occurs when electronic printed circuit cards are improperly handled and can result in complete or intermittent failures. Do the following to prevent ESD:

- Always follow ESD prevention procedures when removing and replacing cards.
- Wear an ESD-preventive wrist strap, ensuring that it makes good skin contact. Connect the clip to an unpainted surface of the chassis frame to safely channel unwanted ESD voltages to ground.
- To properly guard against ESD damage and shocks, the wrist strap and cord must operate effectively. If no wrist strap is available, ground yourself by touching the metal part of the chassis.

General observations

- Clean the case with a soft slightly moist anti-static cloth
- Place the unit on a flat surface and ensure free air circulation
- Avoid exposing the unit to direct sunlight and other heat sources
- Protect the unit from moisture, vapors, and aggressive liquids

Typographical conventions used in this document

This section describes the typographical conventions and terms used in this guide.

General conventions

The procedures described in this manual use the following text conventions:

Table 1. General conventions

Convention	Meaning
Garamond blue type	Indicates a cross-reference hyperlink that points to a figure, graphic, table, or section heading. Clicking on the hyperlink jumps you to the reference. When you have finished reviewing the reference, click on the Go to Previous View button  in the Adobe® Acrobat® Reader toolbar to return to your starting point.
Helvetica bold type	Commands and keywords are in boldface font.
Helvetica bold-italic type	Parts of commands, which are related to elements already named by the user, are in <i>boldface italic</i> font.
<i>Italicized Helvetica type</i>	Variables for which you supply values are in <i>italic</i> font
Helvetica type	Indicates the names of fields or windows.
Garamond bold type	Indicates the names of command buttons that execute an action.
< >	Angle brackets indicate function and keyboard keys, such as <SHIFT>, <CTRL>, <C>, and so on.
[]	Elements in square brackets are optional.
{ a b c }	Alternative but required keywords are grouped in braces ({ }) and are separated by vertical bars ()
blue screen	Information you enter is in blue screen font.
screen	Terminal sessions and information the system displays are in screen font.
node	The leading IP address or nodename of a SmartNode is substituted with <i>node</i> in <i>boldface italic</i> font.
SN	The leading SN on a command line represents the nodename of the SmartNode
#	An hash sign at the beginning of a line indicates a comment line.

Chapter 1 **General Information**

Chapter contents

SmartNode 5570 Overview	15
SmartNode 5570 Rear Panel	16
Ports descriptions	16
SmartNode 5570 Front Panel	18

SmartNode 5570 Overview

The SmartNode 5570 Enterprise Session Border Router (ESBR) (see [figure 1](#)) comes with built-in security features such as SIP TLS, SRTP, stateful firewall, and secure provisioning to protect the LAN networks from fraud strikes out of the Internet. For survivability use cases the PRI (E1/T1) ports can be used for local PSTN break-out. The PRI ports can be used to connect legacy equipment to any VOIP network as well. Like any other Trinity device, the 5570 comes with the built in WEB Wizard for ease of use.

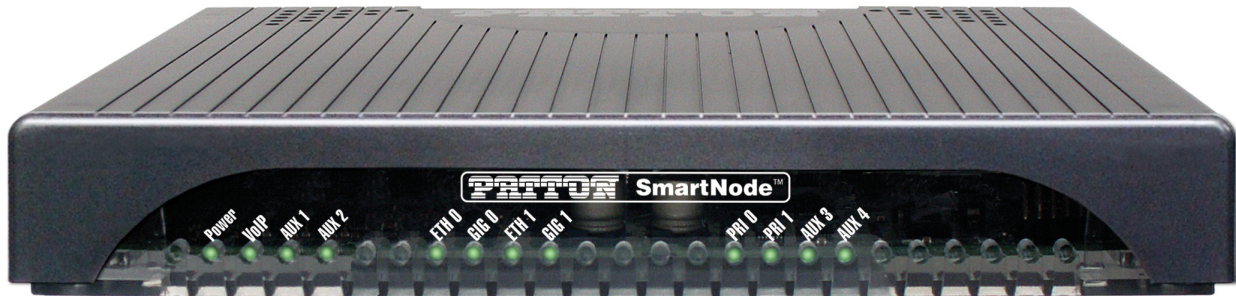

Figure 1. SmartNode 5570 (Front)

The SmartNode 5570 series consists of several models: see the complete SKU list on the corresponding product page on www.patton.com.

All the SN5570 models come equipped with two 10/100/1000 Base-T Ethernet ports and with either 1 or 2 PRI (E1/T1) ports.

The SmartNode 5570 ESBR performs the following major functions:

- 30 channels of Voice over IP and local voice switching via 1 or 2 ISDN PRI E1/T1 ports. Each port can be switched between NT and TE per software. However the port pin-out stays always the same. Also consider the different pinout for port 0/1. Either port can be used as a clock source. Selected models have a Stratum 3 CO quality clock (HP) for installs where no external clock source is available.
- Depending on the model, a fallback cut-through relay between ISDN PRI ports 0/0 and 0/1 electrically connects the NT and TE port in case of power failure and enables life-line calls to the public ISDN network (PSTN-supplied ISDN line must be used).
- Standard compliant VoIP in accordance with SIPv2 protocol.
- Supports 15 SIP to SIP calls and can be license upgraded to a total of 512* (additional cost)
- Internet access and IP Routing with IP Quality of Service (QoS) support for mixed voice and data traffic.
- SIP registrar, SIP TLS, and SRTP are available on all SN5570 models.
- USB 2.0 host port for 3G/4G modem support, which can be used for Survivability applications as a data backup link.
 - A list of supported USB Models can be found in the release notes and in the Trinity Release 3.5.x- Command Line Reference Guide.

-*Supported under ideal conditions. Transcoding, debugging, and/or IP routing reduce processing capacity.

SmartNode 5570 Rear Panel

The SmartNode 5570 is a compact Enterprise Session Border Router that supports 30 VoIP or Fax calls, by using either G.711, G.722, T.38 or any other codec as indicated under Voice Processing in Appendix B, “Specifications” on page 38. The SmartNode 5570 rear panel ports are described in [table 2](#) on page 16.



Figure 2. SN5570 Rear Panel

Ports descriptions

The SmartNode 5570 Series rear panel ports are described in [table 2](#).

Table 2. Rear panel ports

Port	Description
ETH 0/0 & ETH 0/1	Auto-MDX Fast-/Gigabit-Ethernet port, RJ45 (see figure 2), connects the unit to an Ethernet WAN device (for example, a cable modem, DSL modem, or fiber modem).
USB 2.0	USB 2.0 host port (see figure 2) to connect a USB 3G/4G Cellular Modem. A list of supported USB Models can be found in the release notes and in the Trinity Release 3.5.x- Command Line Reference Guide
PRI 0/0 - PRI 0/1	RJ-45 connector providing E1 or T1 PRI interface, meeting all requirements of ITU-T recommendations for G.703. Use a shielded E1 or T1 interface cable for 120 Ohm balanced connections to connect the SmartNode with an NT or TE. Note Port 0/1 uses a different pin-out than 0/0. Port 0/1 is intended to be connected to a PBX and port 0/0 to the PSTN by using a straight cable for both ports. Different usage may require a PRI cross-over cable. Note Refer to Appendix C on page 42 for cabling and Appendix D on page 47 for pin-outs

Table 3. Rear Panel Ports (Continued)

Port	Description
Console	<p>Used for service and maintenance, the console port (see figure 2 on page 16) an RS-232 RJ-45 connector, connects the product to a serial terminal such as a PC or ASCII Terminal (also called a dumb terminal). Configuration settings:</p> <ul style="list-style-type: none"> • 19200 bps • 8 bits, no parity • 1 stop bit • flow control off
12V DC, 1A	Electricity supply socket. (see figure 2 on page 16)
Reset	<p>The reset button (see figure 2 on page 16) has three functions:</p> <ul style="list-style-type: none"> • Restart the unit with the current startup configuration—Press (for less than 1 second) and release the <i>Reset</i> button to restart the unit with the current startup configuration. • Restart the unit with factory default configuration (shipping-config)— Press the <i>Reset</i> button for at least 5 seconds but no longer than 15 seconds until all LEDs (see figure 3 on page 18) starts to blink, to restart the unit with factory default configuration. • Restart the unit with factory default configuration (shipping-config and factory delivered Wizard files) and remove Wizard files added by user as well as user uploaded preference files — Press the <i>Reset</i> button for 15 or more seconds until all LEDs blink faster

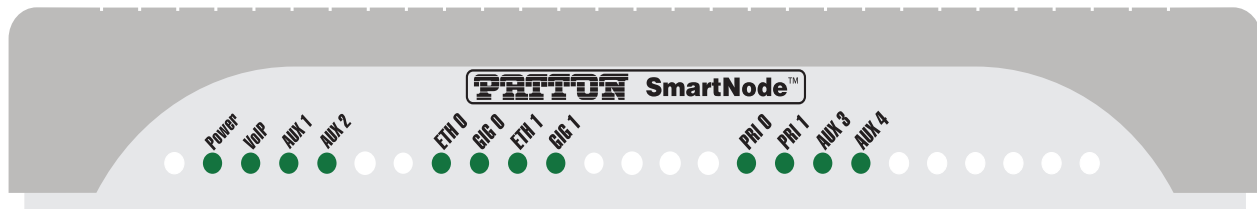

Figure 3. SmartNode 5570 front panel

SmartNode 5570 Front Panel

Figure 3 shows SmartNode 5570 LEDs, the LED definitions are listed in [table 4](#).

Table 4. SmartNode 5570 LED Definitions

LED	Description
Note	If an error occurs, all LEDs will flash solid for MORE than 5 seconds before the device reboots
Power	When lit, indicates power is applied. Blinks fast during bootloader phase and blinks slow during boot process of Trinity Software. Becomes solid when the system is up and running.
VoIP	<ul style="list-style-type: none"> On indicates the gateway is registered to a SIP server, or, a SIP device has registered to the SN5570. Off indicates the unit is not configured or registered, or has no active direct routed VoIP connection.
AUX 1 – AUX 4	<ul style="list-style-type: none"> Auxiliary LEDs for future use.
PRI 0 – PRI 1	<ul style="list-style-type: none"> On when L1 and L2 are active. Flashes when there are ongoing calls. Off when no line or PBX is connected or the port is shutdown.
ETH 0 – ETH1	<ul style="list-style-type: none"> On when the Ethernet connection on the corresponding port has a link indication. Flashes when data is received or transmitted at the corresponding Ethernet port.
GIG 0 – GIG 1	<ul style="list-style-type: none"> On when the Ethernet is connected to a 1000Mb network. Off when the Ethernet is connected to a 10Mb or 100Mb network or not connected

Chapter 2 **Applications Overview**

Chapter contents

Introduction	20
Application—Edge Intelligence of Enterprise Communication	20
How it works:	21
Application—Multi-service ISDN, Secure VoIP and Data Routing Solution	21

Introduction

Patton's SmartNode ESBRs deliver the features you need for advanced multiservice voice and data network applications. They combine high quality voice-over-IP with powerful *quality* of service routing functions to build professional, secure and reliable VoIP and data networks. This chapter describes typical applications for which this SmartNode is uniquely suited.

Note Detailed configuration information for SmartNode applications can be found online at:
<http://www.patton.com/session-border-controller/>.

Application—Edge Intelligence of Enterprise Communication

Enterprises are excited about voice over IP and convergence for the following reasons:

- Bypassing the PSTN. Using Internet telephony service providers (ITSPs) instead of incumbent carriers dramatically reduces telephony costs
- IP PBXs, with their full suite of features and ease of integration into existing IT environments are very appealing
- Convergence lowers technology ownership costs and enables enterprises to deploy new integrated applications

However, there are several concerns about migrating the whole telephony infrastructure to VoIP:

- Loss of voice quality
- Unknown reliability
- Lack of experience/expertise in voice over IP
- VoIP Security concerns

Patton's SmartNode series of ESBRs address these concerns enabling enterprises to safely migrate to VoIP. SmartNodes enable system administrators to gradually introduce VoIP, using it as the edge communication device for all worlds, connecting PSTN, legacy PBX, ITSPs and an IP PBX.

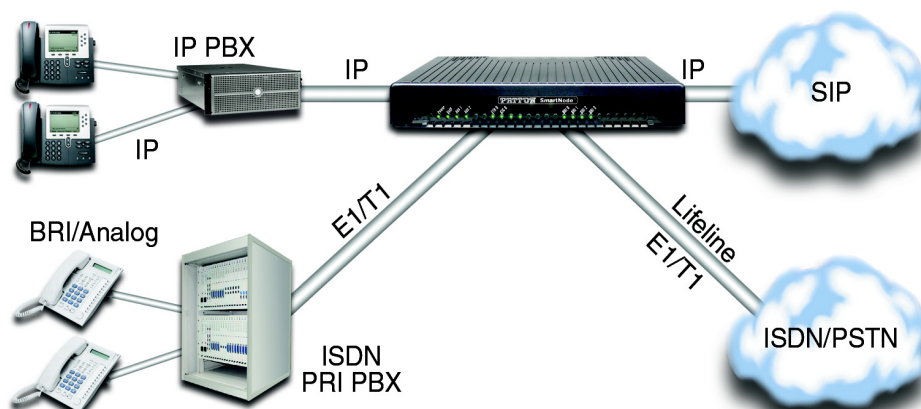

Figure 4. Edge intelligence of enterprise communication application

How it works:

1. Connect the SmartNode to the PSTN and legacy PBX, and configure the call router to pass all calls from the PBX to the PSTN and vice versa. This first step will not affect any uses in the enterprise
2. Choose your ITSPs, and configure as many on the SmartNode as you need. Use the intelligent call router in the SmartNode to decide which call is forwarded to which ITSP, and which calls should go to the PSTN. This may be based upon least-cost routing criteria, or for example, on calling party number. The latter is ideal if you want to test calls to an ITSP before enabling it for all users within the enterprise. As far as supported by the ITSP, the SIP signaling but also the Media can be sent and received encrypted using SIP TLS and SRTP.
3. Voice over IP can be switched off instantly on one single box (the SmartNode) to revert the system back to as it was before.
4. Build up an IP PBX system that uses the SmartNode as PSTN gateway. For all calls from this IP PBX, you can direct them to the PSTN or to ITSPs. Numbering plan adaptations are handled through regular expression matching by the SmartNode. No need to change anything on the PBXs.
5. Once the IP PBX is ready, you can choose on incoming calls from the PSTN, for each extension whether this extension is to be directed to the IP PBX or on the legacy PBX.

Application—Multi-service ISDN, Secure VoIP and Data Routing Solution

The SmartNode 5570 Series can be used to make and receive calls to and from the public ISDN network and internet telephony services on any ISDN PRI PBX (see Figure 5). Using individually configurable routing tables, an outbound call can be directed to the local PSTN connection or to an Internet telephony service provider (ISTP). Inbound calls from the Internet and the PSTN can ring the same phone.

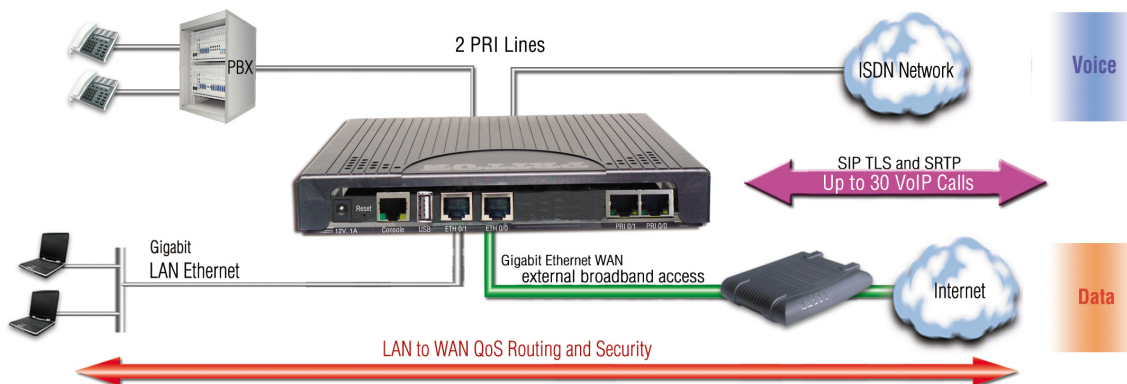

Figure 5. Multi-service ISDN, Secure VoIP and Data Routing Solution

Broadband network connectivity integrates with any fixed IP, DHCP or PPPoE service. An integrated 10/100/1000 Ethernet LAN port, with advanced routing features such as NAT, Stateful-Firewall/ACL, DynDNS, packet-based routing, etc, fulfills the requirements of demanding network users.

Quality of Service (QoS) features complete the offering with advanced voice prioritization and traffic management. Patton's patent-pending DownStreamQoS™ ensures voice without interruptions even over best-effort Internet connections.

Chapter 3 SmartNode Installation

Chapter contents

- Planning the Installation.....23
 - Site log23
 - Network information23
 - Network Diagram23
 - IP related information23
 - Software tools24
 - Power source24
 - Location and mounting requirements24
- Installing the Patton SmartNode ESBR.....24
 - Placing the SmartNode24
 - Installing cables24
 - Connecting ISDN PBX and NT to the SmartNode’s ISDN PRI ports25
 - Connecting the 10/100/1000Base-T Ethernet LAN and WAN cables25
 - Connecting the Power Supply26

Planning the Installation

Before installing the SmartNode device, the following tasks should be completed:

- **Create a network diagram** (see section “[Network information](#)” on page 23)
- **Gather IP related information** (see section “[IP related information](#)” on page 23 for more information)
- **Install the hardware and software needed to configure the SmartNode.** (See section “[Software tools](#)” on page 24)
- **Verify power source reliability** (see section “[Power source](#)” on page 24).

When you finish preparing for SmartNode installation, go to section “[Installing the Patton SmartNode ESBR](#)” on page 24 to install the device.

Site log

Patton recommends that you maintain a site log to record all actions relevant to the system, if you do not already keep such a log. Site log entries should include information such as listed in Table 5.

Table 5. Sample site log entries

Entry	Description
Installation	Make a copy of the installation checklist and insert it into the site log
Upgrades and maintenance	Use the site log to record ongoing maintenance and expansion history
Configuration changes	Record all changes and the reasons for them
Maintenance	Schedules, requirements, and procedures performed
Comments	Notes, and problems
Software	Changes and updates to Trinity software

Network information

Network connection considerations that you should take into account for planning are described for several types of network interfaces in the following sections.

Network Diagram

Draw a network overview diagram that displays all neighboring IP nodes, connected elements and telephony components.

IP related information

Before you can set up the basic IP connectivity for your SmartNode 5570 you should have the following information:

- IP addresses used for Ethernet LAN and WAN ports
- Subnet mask used for Ethernet LAN and WAN ports
- IP addresses and/or URL of SIP servers or Internet telephony services (if used)

- Login and password for PPPoE Access
- Login and Password for SIP based telephony services
- IP addresses of central TFTP server used for configuration upload and download (optional)

Software tools

You will need a PC (or equivalent) with Windows Telnet or a program such as Tera Term Pro or Putty to configure the software on your SmartNode router.

Also you may use your WEB browser to configure the unit. The Web wizard in this case reduces time to get your unit up and running. See more details on the [Knowledgebase](#).

Power source

If you suspect that your AC power is not reliable, for example if room lights flicker often or there is machinery with large motors nearby, have a qualified professional test the power. Patton recommends that you include an uninterruptible power supply (UPS) in the installation to ensure that VoIP service is not impaired if the power fails.

Location and mounting requirements

The SmartNode router is intended to be placed on a desktop or similar sturdy, flat surface that offers easy access to cables. Allow sufficient space at the rear of the chassis for cable connections. Additionally, you should consider the need to access the unit for future upgrades and maintenance.

Installing the Patton SmartNode ESBR

SmartNode ESBR installation consists of the following:

- Placing the device at the desired installation location (see section “Placing the SmartNode” on page 24)
- Installing the interface and power cables (see section “Installing cables” on page 24)

When you finish installing the SmartNode, go to Chapter 4, “Initial Configuration” on page 27.

Placing the SmartNode

Place the ESBR on a desktop or similar sturdy, flat surface that offers easy access to the cables. The ESBR should be installed in a dry environment with sufficient space to allow air circulation for cooling. In order to prevent overheating and damaging the unit, proper ventilation is required when stacking the device. Please consider the note below:

Note For proper ventilation, leave at least 2 inches (5 cm) to the left, right, front, top, and rear of the SmartNode ESBR.

Installing cables



Do not work on the system or connect or disconnect cables during periods of lightning activity.



The interconnecting cables shall be acceptable for external use and shall be rated for the proper application with respect to voltage, current, anticipated temperature, flammability, and mechanical serviceability.

Connect the cables in the following order:

1. Connect the ISDN PBX and NT to the PRI ports (see section “[Connecting ISDN PBX and NT to the SmartNode’s ISDN PRI ports](#)”)
2. Connect the 10/100/1000Base-T Ethernet LAN and WAN (see section “[Connecting the 10/100/1000Base-T Ethernet LAN and WAN cables](#)”)
3. Connect the power mains cable (see section “[Connecting the Power Supply](#)” on page 26)

Connecting ISDN PBX and NT to the SmartNode’s ISDN PRI ports

The SmartNode comes with one or two ISDN PRI (E1/T1) ports located on the rear panel (see figure 2 on page 16). Both ports (0/0 and 0/1) can be connected to the PSTN (ISDN NT) or to a PBX (ISDN TE). In either case, one PRI cross over cable must be used due to the different pin-out used on port 0/1. However, the application is meant to have the ISDN PBX connected to PRI port 0/1 and the ISDN PSTN to port 0/0. This way a straight trough cable can be used for both connections.



For the ISDN connection to a carrier Network, it shall be connected to a Network Termination Device and not connected directly to an outside POTS line.

Note On Lifeline Relay models (/R option) the PSTN line should be connected to PRI 0/0 and a terminal to PRI 0/1 to benefit from the lifeline function. (See the full list of models on www.patton.com).

For details on the PRI port pinout and ISDN cables, refer to [Appendix C, “Cabling”](#) on page 42 and [Appendix D, “Port pin-outs”](#) on page 47.

Connecting the 10/100/1000Base-T Ethernet LAN and WAN cables

The SmartNode 5570 has automatic MDX (auto-cross-over) detection and configuration on the Ethernet ports. Any of the two ports can be connected to a host or hub/switch with a straight-through wired cable.

1. Connect to the subscriber port of the broadband access modem (DSL, cable, WLL) to ETH 0/0.
2. Connect port ETH 0/1 to your LAN.

For details on the Ethernet port pinout and cables, refer to [Appendix C, “Cabling”](#) on page 42 and [Appendix D, “Port pin-outs”](#) on page 47.

Connecting the Power Supply

Do the following to connect the main power to the Model 5570:

Note *Do not connect the power cord to the AC Mains at this time.*

1. Insert the female end of the AC power supply cable to the mains port (see [figure 2](#) on page 16).



There are no user-serviceable parts in the power supply section of the model SN5570. Contact Patton Electronics Technical Support at support@patton.com for more information

2. Verify that the AC power cord included with your device is compatible with local standards. If it is not, refer to “[Contacting Patton for Assistance](#)” on page 32 to find out how to replace it with a compatible power cord.
3. Connect the male end of the power cord to an appropriate power outlet.

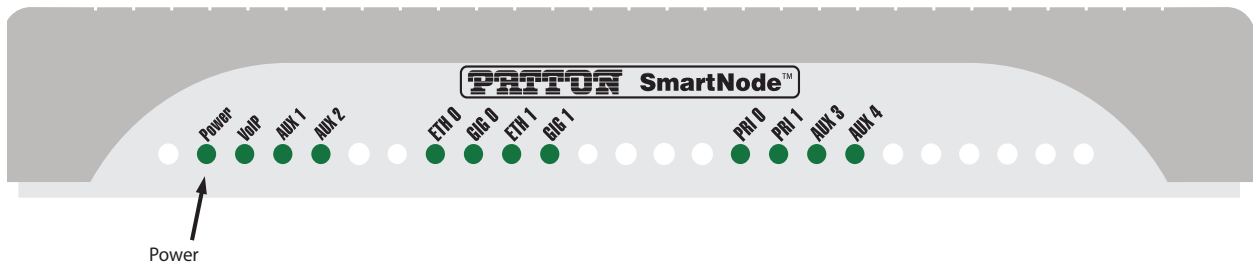

Figure 6. Power LED

4. Verify that the green *Power* LED is lit (see [figure 6](#)). Blinks fast during bootloader phase and blinks slow during boot process of Trinity Software. Becomes solid when the system is up and running.

Congratulations, you have finished installing the SmartNode Enterprise Session Border Router! Now go to [Chapter 4](#), “[Initial Configuration](#)” on page 27.

Chapter 4 Initial Configuration

Chapter contents

Introduction	28
Connecting the SmartNode to Your Laptop PC.....	28
Configure the Desired IP Address.....	29
Factory-default IP Settings	29
Login	29
Changing the WAN IP address	29
Connecting the SmartNode to the Network.....	30
Loading the Configuration (optional).....	31
Additional Information	31

Introduction

This chapter leads you through the basic steps to set up a new SmartNode and to download a configuration. Setting up a new SmartNode consists of the following main steps:

Note If you haven't already installed the SmartNode, refer to Chapter 3, "SmartNode Installation" on page 22.

- Connecting the SmartNode to your laptop PC
- Configuring the desired IP address
- Connecting the SmartNode to the network
- Loading the configuration (optional)

Connecting the SmartNode to Your Laptop PC

First, the SmartNode must be connected to the main power supply with the power cable. Wait until the Power LED stops blinking and stays lit constantly. Now the SmartNode is ready.



The interconnecting cables shall be acceptable for external use and shall be rated for the proper application with respect to voltage, current, anticipated temperature, flammability, and mechanical serviceability.



For the ISDN connection to a carrier network, it shall be connected to a network termination device and not connected directly to an outside POTS line.

The SmartNode 5570 Series is equipped with Auto-MDX Ethernet ports, so you can use straight-through cables for host or hub/switch connections (see figure 7).

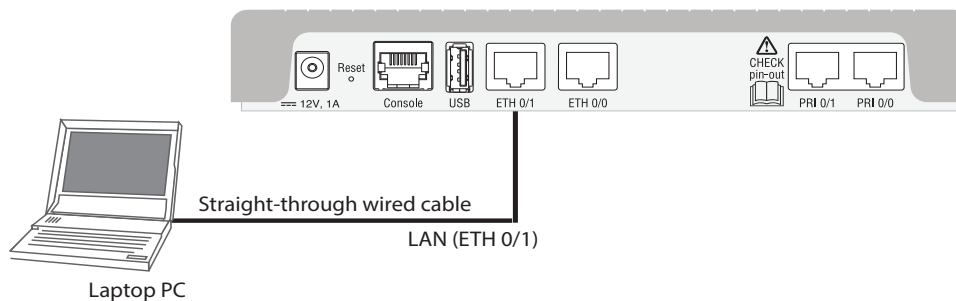

Figure 7. Connecting the SmartNode to your Laptop PC

The SmartNode comes with a built-in DHCP server to simplify configuration. Therefore, to automatically configure the PC for IP connectivity to the SmartNode, the Laptop PC must be configured for DHCP. The SmartNode will provide the PC with an IP address. You can check the connection to the SmartNode by executing the ping command from the PC command window as follows:

```
ping 192.168.1.1
```

Configure the Desired IP Address

Factory-default IP Settings

The factory default configuration for the Ethernet interface IP addresses and network masks are listed in Table 6. Both Ethernet interfaces are activated upon power-up. LAN interface *ETH 0/1 (LAN)* provides a default DHCP server, the WAN interface uses DHCP client to automatically assign the IP address and network mask.

Table 6. Factory Default IP Address and Network Mask Configuration

	IP Address	Network Mask
WAN Interface Ethernet 0 (ETH 0/0)	DHCP	DHCP
LAN Interface Ethernet 1 (ETH 0/1)	192.168.1.1	255.255.255.0
DHCP Address Range	192.168.1.10–192.168.1.99	255.255.255.0

If these addresses match with those of your network, go to section “[Connecting the SmartNode to the Network](#)” on page 30. Otherwise, refer to the following sections to change the addresses and network masks.

Login

To access the SmartNode, start the Telnet application. Type either the host name **smartnode.local**

or the default IP address into the address field of the Telnet application:

192.168.1.1

Accessing your SmartNode via a Telnet session displays the login screen. Type the factory default login: *admin* and leave the password empty. Press the Enter key after the password prompt.

```
login:admin
password: <Enter>
192.168.1.1>
```

After you have successfully logged in you are in the operator execution mode, indicated by > as command line prompt. With the commands *enable* and *configure* you enter the configuration mode.

```
192.168.1.1>enable
192.168.1.1#configure
192.168.1.1 (cfg) #
```

Changing the WAN IP address

Select the context IP mode to configure an IP interface.

```
192.168.1.1 (cfg) #context ip ROUTER
192.168.1.1 (ctx-ip) [ROUTER] #
```

Now you can set your IP address and network mask for the interface *ETH 0/0 (WAN)*. Within this example a network 172.16.1.0/24 address is assumed. The IP address in this example is set to *172.16.1.99* (you should set the IP address given to you by your network provider).

```

192.168.1.1(ctx-ip) [Router]#interface WAN
192.168.1.1(if-ip) [WAN]#no ipaddress DHCP
192.168.1.1(if-ip) [WAN]#ipaddress WAN 172.16.1.99/24
2002-10-28T00:09:40 : LOGINFO      : Link down on interface WAN.
2002-10-29T00:09:40 : LOGINFO      : Link up on interface WAN.
172.16.1.99(if-ip) [WAN]#

```

Copy this modified configuration to your new start-up configuration. This will store your changes in non-volatile memory. Upon the next start-up the system will initialize itself using the modified configuration.

Note The modified configuration is applied immediately. It is not necessary to reboot the device when changing any configuration parameter.

```

172.16.1.99(if-ip) [WAN]#copy running-config startup-config
172.16.1.99(if-ip) [WAN]

```

The SmartNode can now be connected to your network.

Connecting the SmartNode to the Network

In general, the SmartNode will connect to the network via the *WAN (ETH 0/0)* port. This enables the SmartNode to offer routing services to the PC hosts on *LAN (ETH 0/1)* port. The SmartNode 5570 Series is equipped with Auto-MDX Ethernet ports, so you can use straight through or crossover cables for host or hub/switch connections. (see [figure 8](#)).



The interconnecting cables shall be acceptable for external use and shall be rated for the proper application with respect to voltage, current, anticipated temperature, flammability, and mechanical serviceability.



For the ISDN connection to a carrier network, it shall be connected to a network termination device and not connected directly to an outside POTS line.

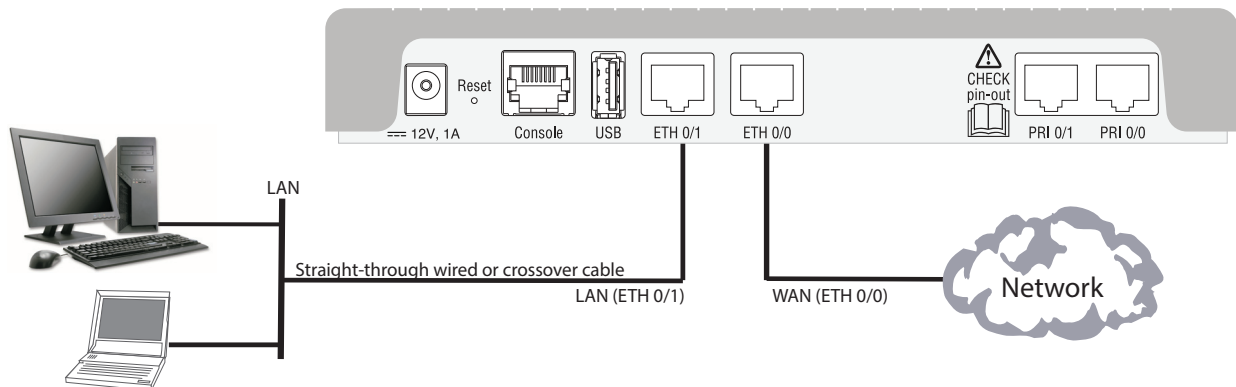

Figure 8. Connecting the SmartNode to the network

You can check the connection with the ping command from the SmartNode to another host on the network.

```
172.16.1.99 (if-ip) [WAN] #ping <IP Address of the host>
```

Note If the WAN address is *not* set to DHCP, to ping a device outside your local LAN you must first configure the default gateway. (For information on configuring the default gateway, refer to section “Set IP addresses” in the Trinity Release 3.5.x– Command Line Reference Guide.)

Note Connecting both ethernet ports to the same switch will only work if the switch has separate ARP tables for each connection.

Loading the Configuration (optional)

Patton provides a collection of configuration templates on the support page at:

<http://www.patton.com/support/kb.asp> —one of which may be similar enough to your application that you can use it to speed up configuring the SmartNode. Simply download the configuration note that matches your application to your PC. Adapt the configuration as described in the configuration note to your network (remember to modify the IP address) and copy the modified configuration to a TFTP server. The SmartNode can now load its configuration from this server.

Note If your application is unique and not covered by any of Patton’s configuration templates, you can manually configure the SmartNode instead of loading a configuration file template. In that case, refer to the SmartNode Series Trinity Release 3.5.x– Command Line Reference Guide for information on configuring the SmartNode device.

In this example we assume the TFTP server on the host with the IP address 172.16.1.11 and the configuration named *SN.cfg* in the root directory of the TFTP server.

```
172.16.1.99 (if-ip) [WAN] #copy tftp://172.16.1.11/sn.cfg startup-config
172.16.1.99 (if-ip) [WAN] #
```

After the SmartNode has been rebooted the new startup configuration will be activated.

```
172.16.1.99 (if-ip) [WAN] #reload
Press 'yes' to restart, 'no' to cancel :yes
The system is going down NOW
```

Additional Information

For detailed information about configuring and operating guidance, set up procedures, and troubleshooting, refer to the Trinity Release 3.5.x– Command Line Reference Guide available online at www.patton.com/manuals.

Chapter 5 **Contacting Patton for Assistance**

Chapter contents

- Introduction 33
- Contact information 33
 - Contacting Patton Technical Services for Free Support 33
- Warranty Service and Returned Merchandise Authorizations (RMAs) 33
 - Warranty coverage 33
 - Out-of-warranty service 34
 - Returns for credit 34
 - Return for credit policy 34
 - RMA numbers 34
 - Shipping instructions 34

Introduction

This chapter contains the following information:

- “[Contact information](#)”—describes how to contact Patton technical support for assistance.
- “[Warranty Service and Returned Merchandise Authorizations \(RMAs\)](#)”—contains information about the warranty and obtaining a return merchandise authorization (RMA).

Contact information

Patton Electronics offers a wide array of free technical services. If you have questions about any of our other products we recommend you begin your search for answers by using our technical knowledge base. Here, we have gathered together many of the more commonly asked questions and compiled them into a searchable database to help you quickly solve your problems.

Contacting Patton Technical Services for Free Support

REGION	North America	Western Europe	Central & Eastern Europe	Middle East North Africa
Location	Maryland, USA	Bern, Switzerland	Budapest, Hungary	Beirut, Lebanon
Time Zone	EST/EDT UTC/GMT - 4/5 hours	CET/CEDT UTC/GMT + 1/2 hours	CET/CEDT UTC/GMT + 1/2 hours	EET/EEDT UTC/GMT + 2/3 hours
Business Hours	Monday-Friday 8:00am to 5:00pm	Monday-Friday 09:00 to 12:00 13:30 to 17:30	Monday-Friday 8:30 to 17:00	Monday-Friday 8:00am to 5pm
Email	support@patton.com	support@patton.com	support@patton.com	support@patton.com
Phone	+ 1 301 975 1007	+41 31 985 25 55	+36 439 3835	+96 1 359 1277
Fax	+1 301 869 9293	+41 31 985 2526		

Warranty Service and Returned Merchandise Authorizations (RMAs)

Patton Electronics is an ISO-9001 certified manufacturer and our products are carefully tested before shipment. All of our products are backed by a comprehensive warranty program.

Note If you purchased your equipment from a Patton Electronics reseller, ask your reseller how you should proceed with warranty service. It is often more convenient for you to work with your local reseller to obtain a replacement. Patton services our products no matter how you acquired them.

Warranty coverage

Our products are under warranty to be free from defects, and we will, at our option, repair or replace the product should it fail within one year from the first date of shipment. Our warranty is limited to defects in workmanship or materials, and does not cover customer damage, lightning or power surge damage, abuse, or unauthorized modification.

Out-of-warranty service

Patton services what we sell, no matter how you acquired it, including malfunctioning products that are no longer under warranty. Our products have a flat fee for repairs. Units damaged by lightning or other catastrophes may require replacement.

Returns for credit

Customer satisfaction is important to us, therefore any product may be returned with authorization within 30 days from the shipment date for a full credit of the purchase price. If you have ordered the wrong equipment or you are dissatisfied in any way, please contact us to request an RMA number to accept your return. Patton is not responsible for equipment returned without a Return Authorization.

Return for credit policy

- Less than 30 days: No Charge. Your credit will be issued upon receipt and inspection of the equipment.
- 30 to 60 days: We will add a 20% restocking charge (crediting your account with 80% of the purchase price).
- Over 60 days: Products will be accepted for repairs only.

RMA numbers

RMA numbers are required for all product returns. You can obtain an RMA by doing one of the following:

- Completing a request on the RMA Request page in the *Support* section at www.patton.com
- By calling +1 (301) 975-1007 and speaking to a Technical Support Engineer
- By sending an e-mail to returns@patton.com

All returned units must have the RMA number clearly visible on the outside of the shipping container. Please use the original packing material that the device came in or pack the unit securely to avoid damage during shipping.

Shipping instructions

The RMA number should be clearly visible on the address label. Our shipping address is as follows:

Patton Electronics Company

RMA#: xxxx

7622 Rickenbacker Dr.

Gaithersburg, MD 20879-4773 USA

Patton will ship the equipment back to you in the same manner you ship it to us. Patton will pay the return shipping costs.

Appendix A **Compliance Information**

Chapter contents

- Compliance36
 - EMC36
 - Safety36
- Radio and TV interference36
- CE Declaration of Conformity36
- Authorized European Representative36
- ISDN Compliance37

Compliance

EMC

- FCC Part 15, Class A
- EN55022, Class A
- EN55024

Safety

- UL60950-1/CSA C22.2 No. 60950-1
- IEC/EN 60950-1, 2nd edition
- AS/NZS 60950-1

Radio and TV interference

The SmartNode router generates and uses radio frequency energy, and if not installed and used properly—that is, in strict accordance with the manufacturer's instructions—may cause interference to radio and television reception. The SmartNode router has been tested and found to comply with the limits for a Class A computing device in accordance with specifications in Subpart B of Part 15 of FCC rules, which are designed to provide reasonable protection from such interference in a commercial installation. However, there is no guarantee that interference will not occur in a particular installation. If the SmartNode router does cause interference to radio or television reception, which can be determined by disconnecting the unit, the user is encouraged to try to correct the interference by one or more of the following measures: moving the computing equipment away from the receiver, re-orienting the receiving antenna and/or plugging the receiving equipment into a different AC outlet (such that the computing equipment and receiver are on different branches).

CE Declaration of Conformity

Patton Electronics, Inc declares that this device is in compliance with the essential requirements and other provisions of Council Directive 1999/5/EC on the approximation of the laws of the member states relating to Radio and Telecommunication Terminal Equipment and the mutual recognition of their conformity.

The safety advice in the documentation accompanying this device shall be obeyed. The conformity to the above directive is indicated by the CE mark on the device.

The signed Declaration of Conformity can be downloaded at www.patton.com/certifications.

Authorized European Representative

D R M Green
European Compliance Services Limited.
Oakdene House, Oak Road,
Watchfield, Swindon, Wilts SN6 8TD, UK

ISDN Compliance

The device is approved for connection to the public ISDN telecommunication network.



For the ISDN connection to a carrier network, it shall be connected to a network termination device and not connected directly to an outside POTS line.

Appendix B **Specifications**

Chapter contents

DSP.....	39
Voice Connectivity.....	39
Data Connectivity.....	39
Voice Processing (signalling dependent).....	39
Fax and modem support.....	40
Voice Signalling.....	40
Voice Routing—session router.....	40
IP Services.....	41
Management.....	41
System.....	41
Physical.....	41

Note Refer to the software feature matrix for the most up-to-date specifications.

DSP

Two 16 channel DSP

Voice Connectivity

1 or 2 ISDN PRI ports, 4-wire

RJ45 ports NT/TE configurable per port (layer 1 pin-out does not change)

Life-line bypass relay between PRI 0/0 and PRI 0/1 ports (Depends on model; /R option)

Data Connectivity

Two 10/100/1000Base-TX Ethernet ports

All ports full duplex, autosensing, auto-MDX

Voice Processing (signalling dependent)

15 to 30 full-duplex channels with Voice CODECS:

- G.711 A-Law/-Law (64 kbps)
- G.722 (64 kbps)
- G.726 (ADPCM 16,24,32,40 kbps)
- G.723.1 (5.3 or 6.3 kbps)
- G.729ab (8kbps)
- Transparent ISDN data

G.168 echo cancellation (128ms)

15 to 30 simultaneous low-bandwidth voice or T.38 fax calls

DTMF detection and generation

Carrier tone detection and generation

Silence suppression and comfort noise

Adaptive and configurable dejitter buffer

Configurable tones (dial, ringing, busy, etc.)

Configurable transmit packet length

RTP/RTCP (RFC 1889)

SRTP (RFC 3711)

Fax and modem support

Automatic fax and modem detection

Codec fallback for modem-bypass

T.38 Fax-Relay (Gr. 3 Fax, 9.6 k, 14.4 K)

G.711 Fax-Bypass

Voice Signalling

SIPv2, SIPv2 over TLS

SIP call transfer, redirect

Overlap or en-bloc dialing

DTMF in-band, out-of-band

Configurable progress tones

Voice Routing—session router

Local switching (hairpinning)

Least cost routing

Interface huntgroups

Call-Distribution groups

Number blocking

Call Routing Criteria:

- Interface
- Calling/called party number
- Time of day, day of week, date
- ISDN bearer capability
- Various other information elements (IEs) of the ISDN setup
- Wildcard and regular expression matching

Regular expression number manipulation functions:

- Replace numbers
- Add/remove digits
- Pattern matching and replacement

IP Services

IPv4 router; IPv6 basic functionalities
Programmable static routes and policy-routing
ICMP redirect (RFC 792); Packet fragmentation
DiffServe/ToS set or queue per header bits
Packet Policing discards excess traffic
DHCP client and server
DNS client and relay-server, DynDNS

Management

Web-based GUI; Trinity WEB Wizard
Industry standard CLI with remote Telnet and SSH access, fully documented
HTTP web management and firmware loading
TFTP configuration & firmware loading
HTTPS configuration & firmware provisioning
SNMP v3 agent (MIB II and private MIB)
Built-in diagnostic tools (trace, debug)
Secure Auto-provisioning

System

Dual Core CPU Broadcom BCM53012 operating at 1GHz
Memory:

- 256 Mbytes DRAM
- 32 Mbytes Flash

Physical

Dimensions: 8.2 x 1.3H x 6.5D inch (20.8W X 3.4H x 16.5D cm)
Weight: <15.9 oz. (<450g)
Power Consumption: <10W
Operating Temperature: 32-104°F (0-40°C)
Operating humidity: up to 90%, non condensing

Appendix C **Cabling**

Chapter contents

Introduction.....	43
Serial Console.....	43
Ethernet	44
ISDN PRI (E1/T1)	45

Introduction

This section provides information on the cables used to connect the SmartNode to the existing network infrastructure and to third party products.

Serial Console

The SmartNode can be connected to a serial terminal over its serial console port, as depicted in figure 9.



The interconnecting cables shall be acceptable for external use and shall be rated for the proper application with respect to voltage, current, anticipated temperature, flammability, and mechanical serviceability.



For the ISDN connection to a carrier network, it shall be connected to a network termination device and not connected directly to an outside POTS line.

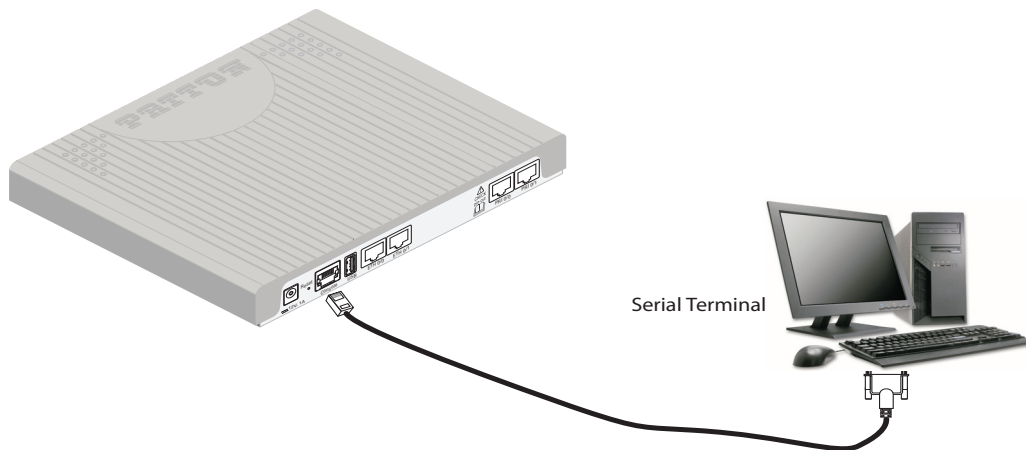

Note A Patton Model 16F-561 RJ45 to DB-9 adapter is included with each SmartNode Series device

Figure 9. Connecting a serial terminal

Console Connection settings:

- 19200 Bps
- 8bits, no parity
- 1stop bit
- flow control off

Note See section “[Console port](#)” on page 48 for console port pin-outs.

Ethernet

Ethernet devices (10/100/1000 Base-T) are connected to the SmartNode over a cable with RJ-45 plugs. All Ethernet ports on the SN5570 are Auto-MDX. Use any straight or crossover cable to a host, hubs, switches, PCs or other devices.



The interconnecting cables shall be acceptable for external use and shall be rated for the proper application with respect to voltage, current, anticipated temperature, flammability, and mechanical serviceability.



For the ISDN connection to a carrier network, it shall be connected to a network termination device and not connected directly to an outside POTS line.

Note Connecting both ethernet ports to the same switch will only work if the switch has separate ARP table for each connection.

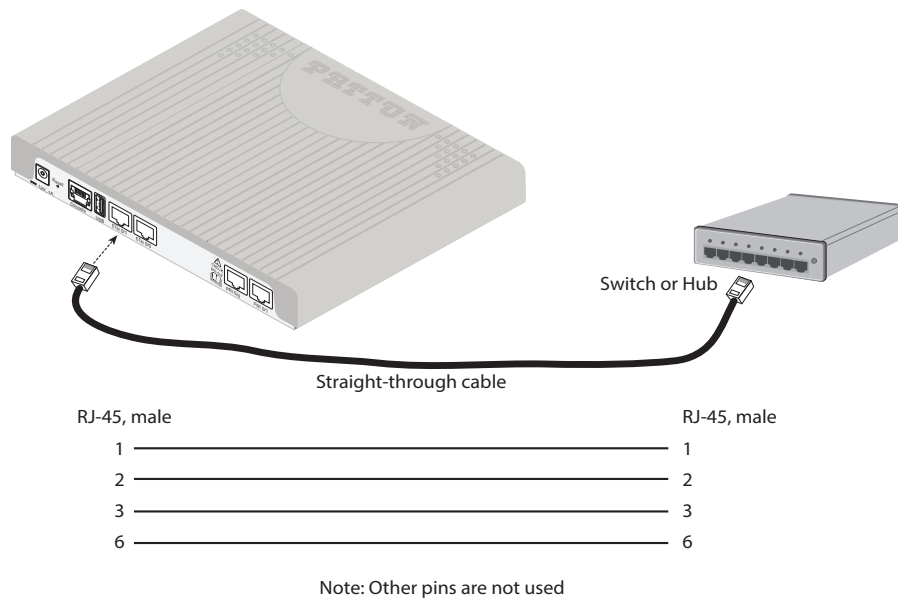

Figure 10. Typical Ethernet straight-through cable diagram for 10/100Base-T

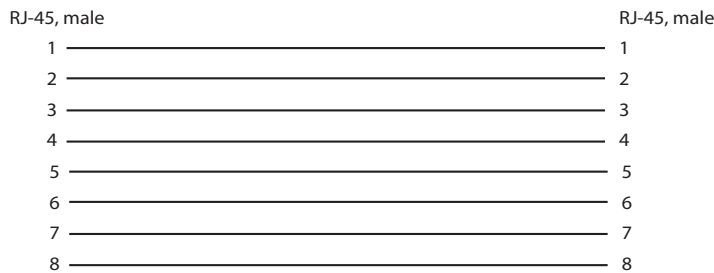

Figure 11. Typical Ethernet straight-through cable diagram for 1000Base-T

ISDN PRI (E1/T1)

The E1/T1 PRI port 0/1 is usually connected to a PBX or switch—local exchange (LE). Type and pin outs of these devices vary depending on the manufacturer. In most cases, a straight-through RJ-45 to RJ-45 can be used to connect the PRI port 0/1 with a PBX.

The E1/T1 PRI port 0/0 is usually connected to a PSTN NT. In most cases, a straight-through RJ-45 to RJ-45 can be used to connect.

Note Note: Port 0/1 uses a different pin-out than port 0/0. This avoids the usage of a PRI cross-over cable when connecting the PBX to port 0/1 and the PSTN NT to port 0/0.

In case both ports have to be connected to a PBX, one port requires a PRI cross-over cable. The same applies when connecting both ports to the PSTN.

The pin-out of a cross-over cable is illustrated in [figure 13](#) on page 46.



CAUTION

Hazardous network voltages are present in the PRI cables. If you detach the cable, detach the end away from the SmartNode or interface card first to avoid possible electric shock. Network hazardous voltages may be present on the device in the area of the PRI port, regardless of when power is turned OFF.



CAUTION

To prevent damage to the system, make certain you connect the PRI cable to the PRI port only and not to any other RJ-45 socket.

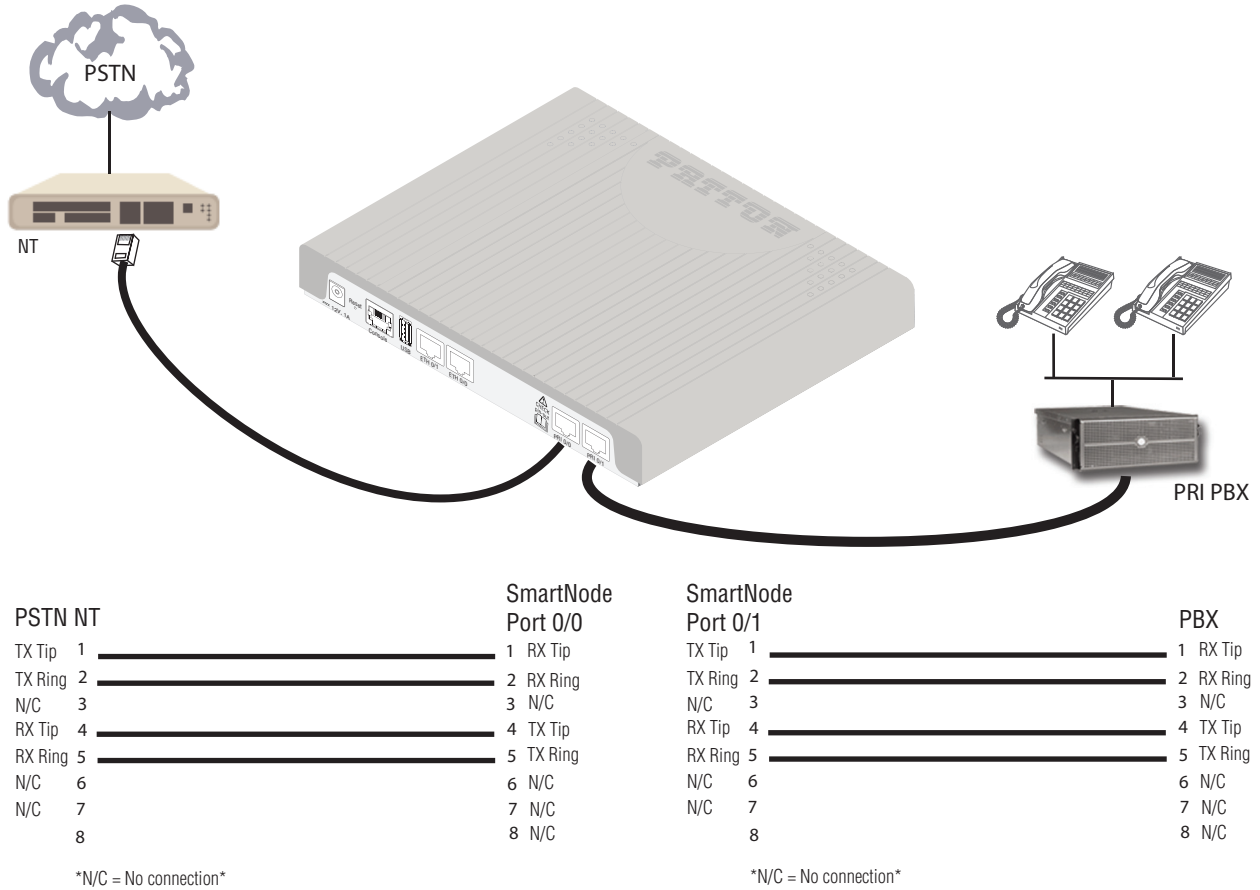

Figure 12. PRI E1/T1 Cabling

In case both ports will be connected to a PBX or to the PSTN, one port requires a PRI cross-over cable.

- Both ports connected to PSTN: Port 0/1 requires a PRI cross-over cable
- Both ports connected to PBX: Port 0/0 requires a PRI cross-over cable

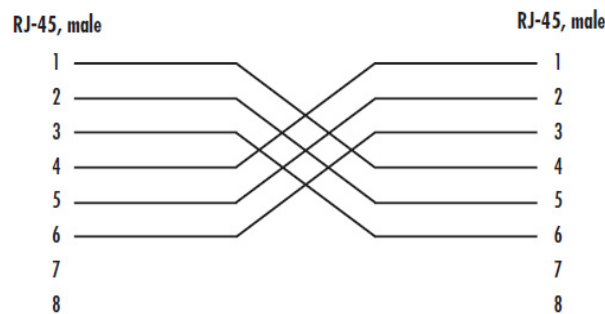

Figure 13. PRI E1/T1 cross-over cable

Appendix D **Port pin-outs**

Chapter contents

Introduction.....	48
Console port.....	48
Ethernet	48
ISDN PRI (E1/T1) Port Pin-outs.....	49

Introduction

This section provides pin-out information for the ports of the SmartNode.

Console port

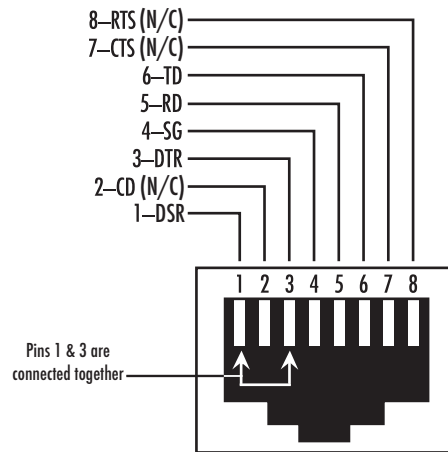

Figure 14. EIA-561 (RJ-45 8-pin) port

Note N/C means no internal electrical connection.

Console Connection Settings:

- 19200bps
- 8 bits, no parity
- 1 stop bit
- flow controls off

Ethernet

Table 7. 10/100 Base-T RJ-45 socket

Pin	Signal
1	TX+
2	TX-
3	RX+
6	RX-

Note Pins not listed are not used.

Table 8. 1000Base-T RJ-45 Socket

Pin	Signal
1	TRD0+
2	TRD0-
3	TRD1+
4	TRD1-
5	TRD2+
6	TRD2-
7	TRD3+
8	TRD3-

ISDN PRI (E1/T1) Port Pin-outs

Table 9. Port 0/0

Pin	Signal
1	RX_TIP
2	RX_RING
3	NC
4	TX_TIP
5	TX_RING
6	NC
7	NC
8	NC

Table 10. Port 0/1

Pin	Signal
1	TX_TIP
2	TX_RING
3	NC
4	RX_TIP
5	RX_RING
6	NC
7	NC
8	NC

Note Pins not listed are not used

Note All pins between the port PRI 0/0 and the port PRI 0/1 are connected during power failure. Fallback relay operation (depending on Model. Only for Models with /R in Product code)

Appendix E **SmartNode 5570 Factory Configuration**

Chapter contents

Introduction.....	51
-------------------	----

Introduction

The factory configuration settings for SmartNode 5570 series can be obtained with the following command through the CLI;

```
login: admin
password: <Enter>
192.168.1.1>show config:shipping-config
```

Please see Chapter 4, "[Initial Configuration](#)" on page 27 for more details about IP address settings for initial configuration.

Appendix F **End User License Agreement**

Chapter contents

- End User License Agreement 53
 - 1. Definitions 53
 - 2. Title 53
 - 3. Term 53
 - 4. Grant of License 53
 - 5. Warranty 53
 - 6. Termination 54
 - 7. Other Licenses 54

End User License Agreement

By operating this package, operating the Designated Equipment or downloading the Programs electronically, the End User agrees to the following conditions:

1. Definitions

- A) Effective Date shall mean the earliest date of purchase or download of a product containing the Patton Electronics Company Program(s) or the Program(s) themselves.
- B) Program(s) shall mean all software, software documentation, source code, object code, or executable code.
- C) End User shall mean the person or organization which has valid title to the Designated Equipment.
- D) Designated Equipment shall mean the hardware on which the Program(s) have been designed and provided to operate by Patton Electronics Company.

2. Title

Title to the Program(s), all copies of the Program(s), all patent rights, copyrights, trade secrets and proprietary information in the Program(s), worldwide, remains with Patton Electronics Company or its licensors.

3. Term

The term of this Agreement is from the Effective Date until title of the Designated Equipment is transferred by End User or unless the license is terminated earlier as defined in section, “6. Termination” on page 54.

4. Grant of License

- A) During the term of this Agreement, Patton Electronics Company grants a personal, non-transferable, non-assignable, and non-exclusive license to the End User to use the Program(s) only with the Designated Equipment at a site owned or leased by the End User.
- B) The End User may copy licensed Program(s) as necessary for backup purposes only for use with the Designated Equipment that was first purchased or used, or its temporary or permanent replacement.
- C) The End User is prohibited from disassembling; decompiling, reverse-engineering or otherwise attempting to discover or disclose the Program(s), source code, methods, or concepts embodied in the Program(s) or having the same done by another party.
- D) Should End User transfer title of the Designated Equipment to a third party after entering into this license agreement, End User is obligated to inform the third party in writing that a separate End User License Agreement from Patton Electronics Company is required to operate the Designated Equipment.

5. Warranty

The Program(s) are provided as is without warranty of any kind. Patton Electronics Company and its licensors disclaim all warranties, either express or implied, including but not limited to the implied warranties of merchantability, fitness for a particular purpose or non-infringement. In no event shall Patton Electronics Company or its licensors be liable for any damages whatsoever (including, without limitation, damages for loss of business profits, business interruption, loss of business information, or other pecuniary loss) arising out of the use of or inability to use the Program(s), even if Patton Electronics Company has been advised of the possibility of such damages. Because some states do not allow the exclusion or limitation of liability for consequential or incidental damages, the above limitation may not apply to you.

If the Program(s) are acquired by or on behalf of a unit or agency of the United States Government, the Government agrees that such Program(s) are commercial computer software or computer software documentation and that, absent a written agreement to the contrary, the Government's rights with respect to such Program(s) are limited by the terms of this Agreement, pursuant to Federal Acquisition Regulations 12.212(a) and/or DEARS 227.7202-1(a) and/or sub-paragraphs (a) through (d) of the "Commercial Computer Software-Restricted Rights" clause at 48 C.F.R. 52.227-19 of the Federal Acquisition Regulations as applicable.

6. Termination

- A) The End user may terminate this agreement by returning the Designated Equipment and destroying all copies of the licensed Program(s).
- B) Patton Electronics Company may terminate this Agreement should End User violate any of the provisions of section, "4. Grant of License" on page 53.
- C) Upon termination for A or B above or the end of the Term, End User is required to destroy all copies of the licensed Program(s).

7. Other Licenses

The Program may be subject to licenses extended by third parties. Accordingly, Patton Electronics Company licenses the Programs subject to the terms and conditions dictated by third parties. Third party software identifies to the Programs includes:

- A routing license is included at no charge. As well as the SIP-TLS and SRTP license.
- ISDN QSIG support will require the purchase of an additional license.
- The LGPL (Lesser General Public License) open source license distributed to you pursuant to the LGPL license terms (<http://www.gnu.org/licenses/lgpl.html>).
- U-Boot (Red Hat Embedded Debug and Bootstrap) embedded system debug/bootstrap environment from Red Hat distributed to you pursuant to the eCos license terms (<http://ecos.sourceware.org/license-overview.html>) and GNU General Public License (GPL) terms (<http://www.gnu.org/copyleft/gpl.html>). Source code is available upon request.