

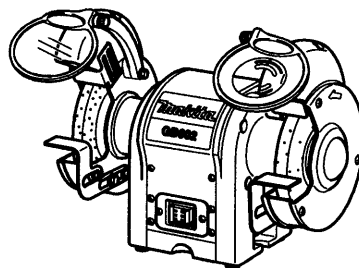

GB BENCH GRINDER	Instruction manual
F Touet	Manuel d'instructions
D Tischschleifer	Betriebsanleitung
I Smerigliatrice da banco	Istruzioni per l'uso
NL Tafelslijpmachine	Gebruiksaanwijzing
E Amoladora de banco	Manual de instrucciones

GB602
GB602W
GB801



GB602/GB801

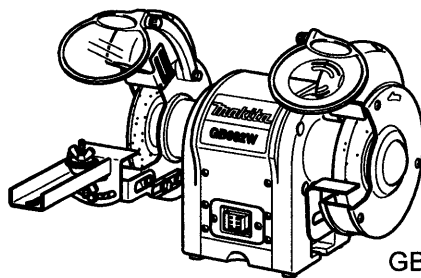

GB602W

ENGLISH

PRODUCT SPECIFICATIONS

Model	GB602	GB602W	GB801
Wheels:			
Diameter	6 in. (150 mm)	6 in. (150 mm) 6 in. (150 mm)	8 in. (205 mm)
Width	5/8 in. (16 mm)	1/4 in. (6.4 mm) 5/8 in. (16 mm)	3/4 in. (19 mm)
Arbor Hole	1/2 in. (12.7 mm)	1/2 in. (12.7 mm) 1/2 in. (12.7 mm)	5/8 in. (15.88 mm)
No load speed (min ⁻¹)	2,850 (50Hz) 3,450 (60Hz)	2,850 (50Hz) 3,450 (60Hz)	2,850 (50Hz) 3,450 (60Hz)
Power Input	250W	250W	550W
Overall length	375 mm	375 mm	395 mm
Net Weight	9.4 kg	9.5 kg	20.5 kg



..... Look for this symbol to point out important safety precautions.
It means attention!! Your safety is involved.

RULES FOR SAFE OPERATION

Safe operation of this power tool requires you read and understand this operator's manual and all labels affixed to the tool. Safety is a combination of common sense, staying alert, and knowing how your bench grinder works.

READ ALL INSTRUCTIONS

- **KNOW YOUR POWER TOOL.** Read the operator's manual carefully. Learn the applications and limitations as well as specific potential hazards related to this tool.
- **GUARD AGAINST ELECTRICAL SHOCK** by preventing body contact with grounded surfaces. For example: pipes, radiators, ranges, and refrigerator enclosures.
- **KEEP GUARDS IN PLACE** and in working order. Never operate the tool with any guard or over removed. Make sure all guards are operating properly before each use.
- **REMOVE ADJUSTING KEYS AND WRENCHES.** Form habit of checking to see keys and adjusting wrenches are removed from tool before turning it on.
- **KEEP THE WORK AREA CLEAN.** Cluttered work areas and workbenches invite accidents.
- **AVOID DANGEROUS ENVIRONMENTS.** Do not use power tools near gasoline or other flammable liquids, in damp or wet locations or expose them to rain. Keep work area well lighted.
- **KEEP CHILDREN AND VISITORS AWAY.** All visitors should wear safety glasses and be kept a safe distance from work area.
- **MAKE WORKSHOP CHILD PROOF** with padlocks, master switches, or by removing starter keys.
- **DON'T FORCE THE TOOL.** It will do the job better and safer at the rate for which it was designed.
- **USE THE RIGHT TOOL.** Do not force the tool or attachment to do a job for which it was not designed.
- **USE THE PROPER EXTENSION CORD.** Make sure your extension cord is in good condition. When using an extension cord, be sure to use one heavy enough to carry the current your product will draw. An undersized cord will cause a drop in line voltage resulting in loss of power and overheating. A wire gauge size (A.W.G) of at least 16 is recommended for an extension cord 8 meters or less in length. If in doubt, use the next heavier gauge. The smaller the gauge number, the heavier the cord.
- **INSPECT EXTENSION CORDS PERIODICALLY** and replace if damaged.
- **WEAR PROPER APPAREL.** Do not wear loose clothing, neckties. Or jewelry that can get caught in the tool's moving parts and cause personal injury. Non-solid footwear is recommended when working outdoors. Wear protective hair covering to contain long hair.
- **ALWAYS WEAR SAFETY GLASSES WITH SIDE SHIELDS.** Everyday eyeglasses are NOT safety glasses.
- **PROTECT YOUR LUNGS.** Wear a face or dust mask if the cutting operation is dusty.
- **PROTECT YOUR HEARING.** Wear hearing protection during extended periods of operation.
- **DON'T ABUSE CORD.** Never carry tool by the cord or yank it to disconnect from receptacle. Keep cord away from heat, oil, and sharp edges.
- **DO NOT OVERREACH.** Keep proper footing and balance at all times.

- **MAINTAIN TOOLS WITH CARE.** Keep tools sharp and clean for best and safest performance. Follow instructions for lubricating and changing accessories.
- **NEVER LEAVE TOOL RUNNING UNATTENDED. TURN POWER OFF.** Disconnect all tools when not in use, before servicing, or when changing attachments, wheels, etc.
- **AVOID ACCIDENTAL STARTING.**
- **USE RECOMMENDED ACCESSORIES.** The use of improper accessories may cause risk of injury.
- **DO NOT use wheels with incorrect size bore. NEVER use wheel washers or wheel that are defective or incorrect and NEVER touch grinding wheel or other moving parts.**
- **NEVER STAND ON TOOL.** Serious injury could occur if the tool is tipped or if the wheel is unintentionally contacted.
- **DIRECTION OF FEED.** Be aware of wheel rotation direction; never grind without the work rest being properly set. NEVER grind more than one workpiece at a time.

⚠ WARNING

Wheel coasts after turn off.

- **CHECK DAMAGED PARTS.** Before further use of the tool, a guard or other part that is damaged should be carefully checked to determine that it will operate properly and perform its intended function. Check for alignment of moving parts, binding of moving parts, breakage of parts, mounting and any other conditions that may affect its operation. A guard or other part that is damaged must be properly repaired or replaced by an authorized service center to avoid risk of personal injury.
- **KEEP TOOL DRY, CLEAN, AND FREE FROM OIL AND GREASE.** Always use a clean cloth when cleaning. Never use brake fluids, gasoline, petroleum-based products, or any solvents to clean tool.
- **INSPECT POWER SUPPLY AND EXTENSION CORDS PERIODICALLY** and, if damaged, have repaired by a qualified service technician. Stay constantly aware of cord location and keep it well away from the rotating wheel.
- **NEVER USE IN AN EXPLOSIVE ATMOSPHERE.** Normal sparking of the motor or sparking from grinding metal could ignite fumes.
- **USE OUTDOOR EXTENSION CORDS.** Use only extension cords with approved ground connection that are intended for use outdoors and so marked.
- **NEVER reach to pick up a workpiece, a piece of scrap, or anything else that is in or near the grinding path of the wheel.**
- **AVOID AWKWARD OPERATIONS AND HAND POSITIONS** where a sudden slip could cause your hand to move into the wheel. ALWAYS make sure you have good balance.
- **NEVER stand or have any part of your body in line with the path of the wheel.**

- **DO NOT USE TOOL IF SWITCH DOES NOT TURN IT ON AND OFF.** Have defective switches replaced by an authorized service center.
- **DO NOT TURN THE MOTOR SWITCH ON AND OFF RAPIDLY.** This could cause the wheel to loosen and could create a hazard. Should this ever occur, stand clear and allow the wheel to come to a complete stop. Disconnect your grinder from the power supply and securely retighten the wheel nut.

⚠ WARNING:

When servicing use only identical replacement parts. Use of any other parts may create a hazard or cause product damage.

- **USE ONLY FLANGES** furnished with this bench grinder.
IF ANY PART OF THIS GRINDER IS MISSING or should break, bend, or fail in any way, or should any electrical component fail to perform properly, shut off the power switch, remove the machine plug from the power source and have damaged, missing, or failed parts replaced before resuming operation.
- **MAKE SURE THE GRINDING IS SECURELY MOUNTED** as described in the operating instructions before connecting the tool to a power supply.
- **DO NOT OVERTIGHTEN THE WHEEL NUT,** excessive tightening cause the wheel to crack during operation.
- **INSPECT GRINDING WHEEL** for visible defects. Check the wheel for fissures and cracks, and test for normal operation prior to use.
- **ADJUST distance between wheel and work rest** to maintain 1.6 mm. or less separation as the diameter of the wheel decreases with use. The value of separation used in the marking is to be the separation recommended by the manufacturer but shall not be more than 3.2 mm.
- **ALWAYS EASE THE WORKPIECE AGAINST THE ABRASIVE WHEEL.** When starting to grind. A harsh impact can break the wheel. Use light pressure when starting to grind; too much pressure on a cold wheel can cause the wheel to crack.
- **RISK OF INJURY DUE TO ACCIDENTAL STARTING.** Do not use in an area where children may be present.
- **NEVER START THE GRINDER** when the wheel is contact with the workpiece.
- **SECURE WORK.** Always hold workpiece firmly against the work rest.
- **DO NOT USE THE BENCH GRINDER** if the flange nut or clamp nut is missing or if the spindle shaft is bent.
- **FREQUENTLY clean grinding dust** from beneath grinder.
- **DO NOT OPERATE THIS TOOL WHILE UNDER THE INFLUENCE OF DRUGS, ALCOHOL, OR ANY MEDICATION.**
- **ALWAYS STAY ALERT.** Do not allow familiarity (gained from frequent use of grinder) to cause complacency.

- A careless fraction of a second is sufficient to inflict severe injury.
- **STAY ALERT AND EXERCISE CONTROL.** Watch what you are doing and use common sense. Do not operate tool when you are tired. Do not rush.
- **SAVE THESE INSTRUCTIONS.** Refer to them frequently and use them to instruct other users. If you loan someone this tool, loan them these instructions also.

▲ WARNING:

Some dust created by power sanding, sawing, grinding, drilling, and other construction activities contains chemicals known to cause cancer, birth defects or other reproductive harm. Some examples of these chemicals are:

- lead from lead-based paints.
- crystalline silica from bricks and cement and other masonry products, and
- arsenic and chromium from chemically treated timber.

Your risk from these exposures varies, depending on how often you do this type of work. To reduce your exposure to these chemicals: work in a well ventilated area, and work with approved safety equipment, such as those dust masks that are specially designed to filter out microscopic particles.



The purpose of safety symbols is to attract your attention to possible dangers. The safety symbols, and the explanations with them, deserve your careful attention and understanding. The safety warning does not by themselves eliminate any danger. The instructions or warning they give are not substitutes for proper accident prevention measures.

SYMBOL	MEANING
	SAFETY ALERT SYMBOL: Indicates danger, warning, or caution. May be used in conjunction with other symbols or pictographs.
	DANGER: Failure to obey a safety warning will result in serious injury to yourself to other. Always follow the safety precautions to reduce the risk fire, electric shock and personal injury.
	WARNING: Failure to obey a safety warning may result in property damage or personal injury to yourself or to others. Always follow the safety precautions to reduce the risk of fire, electric shock and personal injury.
	CAUTION: Failure to obey a safety warning may result in property damage or personal injury to yourself or to others. Always follow the safety precautions to reduce the risk of fire, electric shock and personal injury.
NOTE:	Advises you of information or instructions vital to the operation or maintenance of the equipment.

▲ WARNING:

Do not attempt to operate this tool until you have read thoroughly and understand completely all instructions, safety rules, etc. contained in this manual. Failure to comply can result in accidents involving fire, electric shock, or serious personal injury. Save this operator's manual and review frequently for continuing safe operation and instructing others who may use this tool.



⚠ WARNING:

The operation of any grinding can result in foreign objects being thrown into your eyes, which can result in severe eye damage. Before beginning power tool operation, always wear safety goggles or safety glasses with side shields and a full-face shield when needed. We recommend Wide Vision Safety Mask for use over eyeglasses or standard safety glasses with side shields.

UNPACKING

- Carefully remove all parts from the shipping carton.
 - Lift the bench grinder from the carton and place it on a work surface.
 - Do not discard the packing materials until you have carefully inspected the machine, identified all loose parts, and satisfactorily operated your bench grinder.
 - Examine all parts to make sure no breakage or damage has occurred during shipping.
 - If all parts have been included, proceed to assembly.
- If any parts are damaged or missing, do not attempt to plug in the tool or turn it on until the damaged or missing parts are obtained and installed correctly.
 - Contact your nearest dealer for assistance if parts are missing or damage.

⚠ WARNING:
If any parts are missing do not operate this machine until the missing parts are replaced. Failure to do so could result in possible serious injury.

STANDARD EQUIPMENT

<p>GB602</p> <ul style="list-style-type: none"> ■ Wrench 8-19 1 ■ Wrench 10-13 1 ■ Safety goggles 1 <p>GB801</p> <ul style="list-style-type: none"> ■ Wrench 8-24 1 ■ Wrench 10-13-17 1 ■ Safety goggles 1 	<p>GB602W</p> <ul style="list-style-type: none"> ■ Wrench 8-19 1 ■ Wrench 10-13 1 ■ Left Work Rest 1 ■ Safety goggles 1
--	--

FEATURES

- KNOW YOUR BENCH GRINDER**
See Fig. 3.
Before attempting to use your new tool, familiarize yourself with all operating features and safety requirements.
Carefully read this operator's manual before using your grinder.
- POWER SWITCH**
An easy access On/Off switch convenience and safety.
- MOTOR**
Powered by a precision-built electric induction motor, your bench grinder has sufficient power to handle tough grinding jobs.
- GRINDING WHEEL**
Equipped with coarse and fine grinding wheels to suit most applications.

- NOTE:**
New wheels sometimes require dressing to true up the face of the wheel.
- SAFETY EYE SHIELD AND SPARK DEFLECTOR**
The safety shields and spark deflectors are adjustable for operator convenience. Operating the grinder without these features attached could result in serious injury. Do not grind with the safety shield raised; always wear safety glasses for personal protection.
- WORK REST**
The work rests are independently adjustable to compensate for wheel wear. Before grinding, make certain the work rests are adjusted properly. Generally the object being ground is done slightly above center of the grinding wheel.
Adjust the distance between the wheel and work rest to maintain 1.6 mm. or less separation as diameter of the wheel decreases with use.

With a permanently mounted work light that automatically lights the work area for safer, more accurate grinding and sharpening.

COOLANT TRAY

When grinding, metal objects become heated quickly. It is important to keep moving the object back and forth across the grinding wheel and to cool the object frequently using the grinder's Coolant Tray.

GB602/GB801 (Fig. 3)

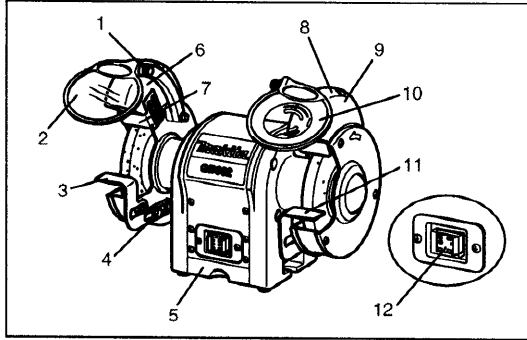

1. Adjustable knob
2. Safety eye shield
3. Work rest (left)
4. Adjustment bolts
5. Coolant tray
6. Auto-ON (work light)
7. Spark deflector (left)
8. Spark deflector (right)
9. Lamp cover
10. Safety eye shield with magnifying glass
11. Work rest (right)
12. Power switch

GB602W (Fig. 4)

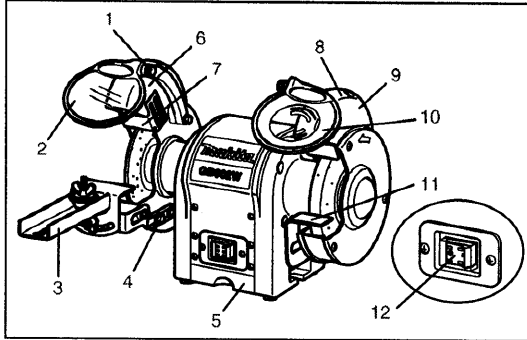

1. Adjustable knob
2. Safety eye shield
3. Saw blade sharpening kit
4. Adjustment bolts
5. Coolant tray
6. Auto-ON (work light)
7. Spark deflector (left)
8. Spark deflector (right)
9. Lamp cover
10. Safety eye shield with magnifying glass
11. Work rest (right)
12. Power switch

ASSEMBLY

MOUNTING SAFETY EYE SHIELDS

See Fig. 5-6.

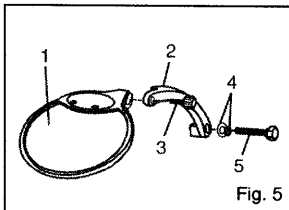

1. Safety eye shield
2. Eye shield mounting arm
3. Adjustable knob
4. Washer
5. Hex bolt

Fig. 5

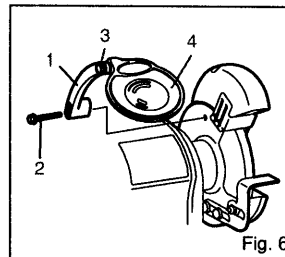

1. Eye shield mounting arm
2. Hex bolt
3. Adjustable knob
4. Safety eye shield

Fig. 6

Mount the left and right eye shield-mounting arm To the inside of the wheel guards using the clamp Brackets, hex bolts (M6 X 30 mm), and washers (6 mm).

Use the illustration as a guide to determine which eyes Shield mounting arm is mounted on the left and which eye

shield mounting arm is mounted on the right of the grinder.

Once eye shield mounting arms are firmly in place, slide the shield bracket onto the eye shield-mounting arm.

Tighten the adjustable knob leaving it loose enough to allow the safety eye shield to be raised and lowered easily.

⚠ WARNING:

To prevent personal injury, never operate the bench grinder unless the safety eye shields and spark deflectors are properly installed and in place.

WORK REST

GB602/GB801/GB602W

See Fig. 7.

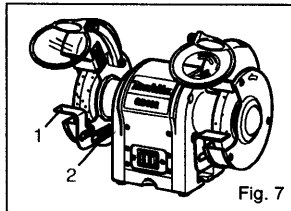

1. Work rest bracket
2. Hex bolt

Mount the work rests to the work rest bracket using the two hex bolts.

Before tightening the bolts, adjust the gap between the Grinding wheel and work rest to a maximum of 1.6 mm.

Tighten securely.

GB602W only

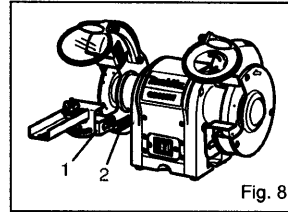

1. Work rest
2. Hex bolt

Mount the blade work rest to the work rest bracket using the two hex bolts.

Before tightening the bolts, adjust the gap between the Grinding wheel and work rest to a maximum of 1.6 mm.

Tighten securely.

OPERATION

BASIC OPERATION

⚠ WARNING:

Always wear safety goggles or safety glasses with side shields during power tool operation or when blowing dust. If operation is dusty, wear a dust mask.

To be efficient and work as designed, your tools should be kept sharp. Dull tools can and will cause accidents.

Bench Grinders are ideal for sharpening tools such as chisels, planer blades, scissors, etc., and for removing rust or corrosion.

⚠ WARNING:

Never sharpen or grind anything made of aluminum.

Grinders remove material rapidly so pressure is the key to efficient grinding.

The proper way to sharpen a tool and avoid overheating is:

- Keep a tool on the work rest firmly at the correct the wheel.
- Keep the object in constant motion, moving it at an even pace.
- Never force a tool against the grinding wheel.
- Keep the tool cool by using either a cooling tray, or a pan of water.
- The grinding wheel should rotate "into" the object being sharpened.

NOTE:

Excessive pressure may damage the tool, cause the motor to overheat, and prematurely wear down the grinding wheel.

⚠ WARNING:

Excessive pressure on a cold wheel cause the wheel to crack.

GB801 only

Balancing the grinding wheel

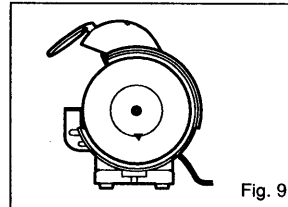

When the grinding wheel only is mounted, the heaviest section will assume the lowest Position. Mark this section as in the Fig. 9.

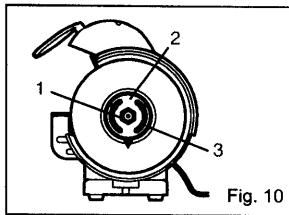

1. Nut
2. Flange
3. Balance weight

Fig. 10

In this condition (Fig. 9) install the flange and balance weight.
The balance weight should be positioned above as seen in the Fig. 10.

Then, temporarily tighten the flange with the installing nut.

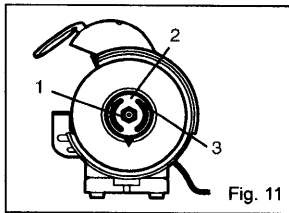

1. Nut
2. Balance weight
3. Stopper screw

Fig. 11

In condition Fig. 10, move the balance weight so that when the wheel is turned it will not stop at the same place but at random. Then fasten the stop screws on the balance weight and firmly tighten the flange nut.

GB602W only

How to attach saw blade-sharpening kit

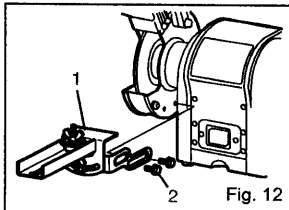

1. Saw blade sharpening kit
2. Bolt

Fig. 12

■ Assembly and attach saw blade sharpening kit as in Fig. 12.

Before using, make sure it is securely fastened.

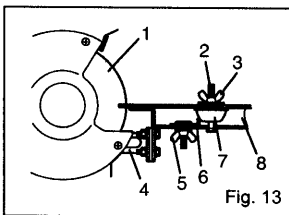

1. Grinding wheel
2. Screw
3. Wing nut A
4. Tool rest holder
5. Wing nut B
6. Stopper
7. Holder B
8. Tool rest

Fig. 13

Place the saw blade between holder A and holder B. Then secure the assembly on the screw with the wing nut A.

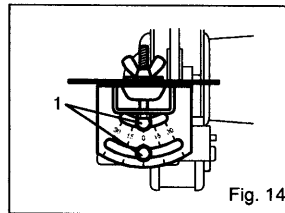

1. Hex bolt

Fig. 14

The angle adjustment can be made by loosening the hex bolts on the bevel scale plate. After adjusting the angle, tighten the hex bolts securely.

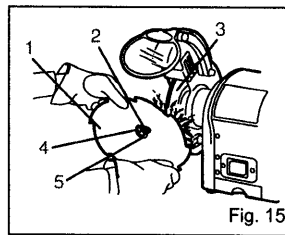

1. Saw blade
2. Screw
3. Grinding wheel
4. Wing nut A
5. Holder A

Fig. 15

Loosen the wing nut B and slide the holder B so that the "gullet" or slot between the saw blade Teeth just comes in contact with the edge of the Wheel. Slide the stopper so that it comes in contact with the holder B and tighten the wing nut B securely.

▲ WARNING:

Always disconnect the bench grinder from the power source before performing any assembly or adjustment.

Failure to do so could result in accidental starting resulting in possible serious personal injury.

WHEEL REPLACEMENT

See Fig. 16.

If you must replace a grinding wheel, be sure to obtain one with a safe rated speed at least as high as the "no load speed" RPM marked on the data plate of the grinder and which is marked to comply with SAA.

To replace the grinding wheel, remove the wheel cover by loosening the screws with holding the nut wrench.

Loosen the wheel nut in a clockwise direction for the left side and a counterclockwise direction for the right side using. Remove the outer flange and grinding wheel. To install a new grinding wheel, reverse the above procedure.

Be sure the grinding wheel and outer flange are properly seated on the spindle shaft.

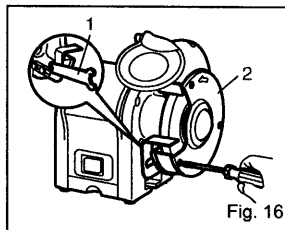

1. Wrench
2. Wheel cover

Fig. 16

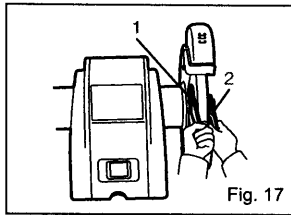

1. Wrench 8
2. Wrench 10

Fig. 17

MAINTENANCE

▲ WARNING:

When servicing, using only replacement parts. Use of other part may create a hazard of cause product damage.

GENERAL

Keep the bench grinder clean. Remove dust from working parts and beneath the grinder frequently.

Make sure the bench grinder operates properly. Check screws, nuts, and bolts for tightness.

EXTENSION CORDS

The use of any extension cord will cause some loss of power. To keep the loss to a minimum and to prevent tool overheating, use an extension cord that is heavy enough to carry the current the tool will draw.

A wire gauge size (A.W.G) of at least 16 is recommended for an extension cord 8 meters or less in length. When working outdoors, use an extension cord that is suitable for outdoor use. The cord's jacket will be marked WA.

▲ WARNING:

Check extension cords before each use. If damaged, replace immediately. Never use tool with damaged cord since touching the damaged area could cause electrical shock resulting in serious injury.

WORKLIGHT BULB REPLACEMENT

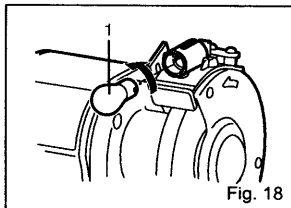

1. Light bulb

Fig. 18

When the light bulb is worn out and no longer working, unfasten the screws which fix the lamp cover, then gently remove the bulb from the holder by pushing in and turning anticlockwise. Contact your dealer for replacement part. To replace, gently push the light bulb into the insert and turn clockwise, then fix the lamp cover in the revise order.

WHEEL DRESSING TOOL (Accessory)

Dressing a wheel is done to renew sharpness or to true up the face of the wheel.

Set the work rest of the bench grinder at a slight angle and brace the wheel-dressing tool against it. Do not make contact with the grinding wheel until after you have turned on the motor and the wheel is rotating at full speed. Press the dressing tool slightly against the rotating wheel until you get a bite, then move slowly from side across the wheel. A small bite and many passes are better than a big bite and one pass. Work cautiously; hold the dresser with force on the work rest. Do not use excessive pressure against the grinding wheel. Proceed solely until you master the technique.

TROUBLESHOOTING

This section covers the most common problems encountered during operation and what to do about them. Do not make any adjustments until machine is unplugged and moving parts have come to a complete stop.

SYMPTOM	POSSIBLE CAUSE	CORRECTIVE ACTION
Motor will not start.	<ol style="list-style-type: none"> 1. Low voltage. 2. Open circuit in motor or loose connections. 	<ol style="list-style-type: none"> 1. Check power line for proper voltage. 2. Inspect all lead connections on motor for loose or open connections.
Motor will not start; fuses or circuit breakers blow	<ol style="list-style-type: none"> 1. Short circuit inline cord or plug. 2. Short circuit in motor or loose connections. 	<ol style="list-style-type: none"> 1. Inspect cord plug for damaged insulation and shorted wires. 2. Inspect all connections on motor for loose or shorted terminals or worn insulation. 3. Install correct fuses or circuit breakers.
Motor overheats.	Motor overloaded.	Reduce load on motor.
Motor stalls (resulting in blown fuses or tripped circuit)	<ol style="list-style-type: none"> 1. Short circuit in motor or loose connections. 2. Low voltage. 3. Incorrect fuses or circuit breakers in power line. 4. Motor overloaded. 	<ol style="list-style-type: none"> 1. Inspect connections on motor for loose or shorted terminals or worn insulation. 2. Correct the low voltage conditions. 3. Install correct fuses or circuit breakers. 4. Reduce load on motor.
Machine slows when operating.	Depth of cut is too great.	Slow down the of rate of movement of the workpiece into wheel.
Wavy condition on surface of workpiece.	<ol style="list-style-type: none"> 1. Make sure machines is securely mounted on a solid surface. 2. Use a holding device to firmly retain the workpiece. 3. Dress the grinding wheel. 4. Use softer wheel, or reduce the feed rate. 	
Lines on surface of workpiece.	<ol style="list-style-type: none"> 1. Impurity on wheel surface. 2. Workpiece not being held tightly. 	<ol style="list-style-type: none"> 1. Dress the grinding wheel. 2. Use a holding device to firmly retain the workpiece.
Burning spots or cracks in the workpiece.	<ol style="list-style-type: none"> 1. Improper type of grinding wheel. 2. Improper feed rate. 3. Coolant required. 	<ol style="list-style-type: none"> 1. Try a wheel which is softer style or coarser grit. 2. Slow down the rate of movement of the workpiece into wheel. 3. Add optional coolant system or introduce coolant by hand.
Wheel dulls quickly, grit falls off.	<ol style="list-style-type: none"> 1. Depth of cut too great. 2. Wheel is too soft for the material being. Select harder bond. 3. Wheel diameter too small. 4. Bad wheel dress. 5. Defective wheel bonding. 	<ol style="list-style-type: none"> 1. Slow down the rate of movement of the workpiece into wheel. 2. Wheel is too hard for the material being. Select softer bond. 3. Replace the wheel. 4. Dress the wheel. 5. Consult manufacturer of grinding wheel.
Wheel clogs and workpiece shows burn marks.	<ol style="list-style-type: none"> 1. Wheel is too hard. 2. Feed rate is too slow. 3. Bad wheel dress. 4. Coolant required. 	<ol style="list-style-type: none"> 1. Select softer bond. 2. Increase the rate of movement of the workpiece into wheel. 3. Dress the wheel. 4. Add optional coolant system or introduce coolant by hand.

Makita Corporation