



SILVERSTONE[®]

ARM One / Two

Single / Dual LCD

interactive arm

Liberate your view

ARM11SC / ARM22SC



ARM One
Single LCD
interactive arm
Liberate your view

A R M 1 1 S C



ARM Two
Dual LCD
interactive arm
Liberate your view

A R M 2 2 S C

Introduction

SilverStone created ARM Series to significantly raise the value and usability of your monitor. ARM11SC/ARM22SC is a clamp mount unit constructed with robust aluminum alloy and steel. It includes VESA Mounting Interface Standard (MIS) which fits most monitors on the market. Hassle-free adjustments can be made for height and reach to provide various viewing angles for the monitor so your view will no longer be restricted to traditional positions.

Features

90 degrees monitor rotation.

Height adjustment

Cable management

Smart torque adjust

Aluminum structure

Easy installation

Meet VESA Mounting Interface Standard.

Specifications

Model No.	SST-ARM11SC / SST-ARM22SC
Material	Steel/Aluminum alloy/Plastic
Color	Silver
Max. wall mount hole pitch	100 x 100 mm/ 75 x 75 mm (MIS-D 75 / MIS-D 100)
Screw Type	M4
Swivel	+/-90°
Tilt	Max. +90° / -20°
Rotate(Pivot)	360°
Support max. monitor weight per arm	10Kg(22.04lbs)
Support desktop thickness	5mm (0.31")~ 50mm (1.96")
Support flat panel size	15"~24"
Extended Arm Provided	ARM11SC: 2 \ ARM22C: 4
Net Weight	3.8Kg (8.37lbs) / 5.7Kg(12.54lb)
Dimension(W x H x D)	ARM11SC: 500 x 497 x 619 mm \ ARM22SC: 1000 x 497 x 619mm

Physical Dimension

ARM11SC

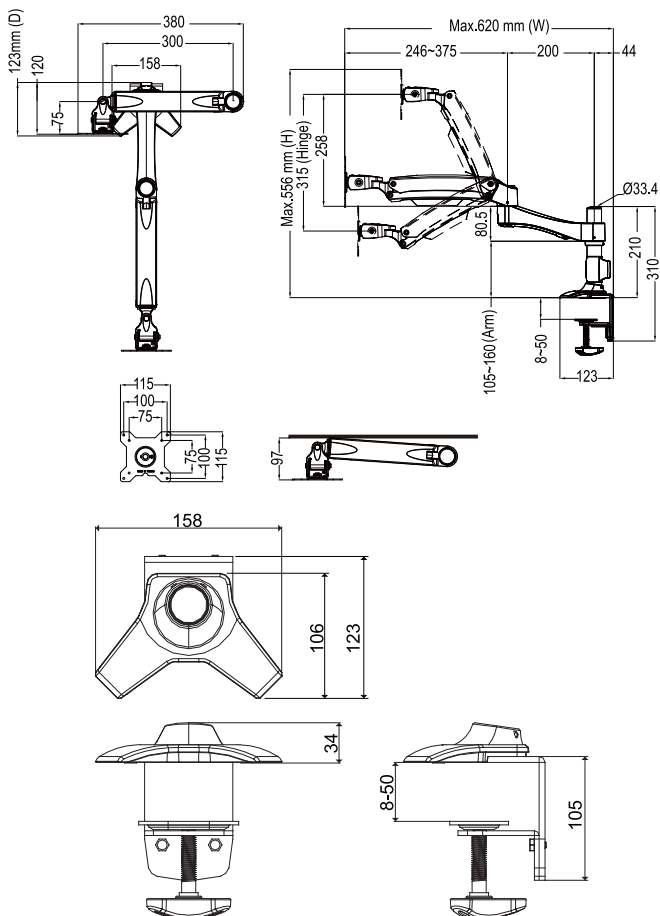

Physical Dimension

ARM22SC

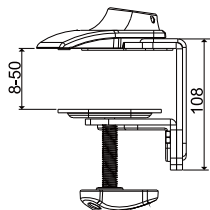
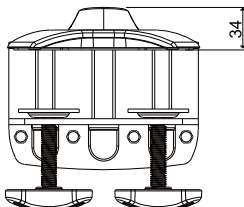
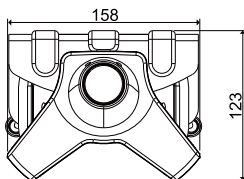
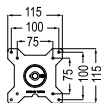
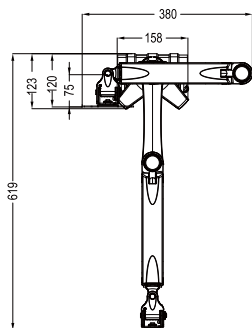
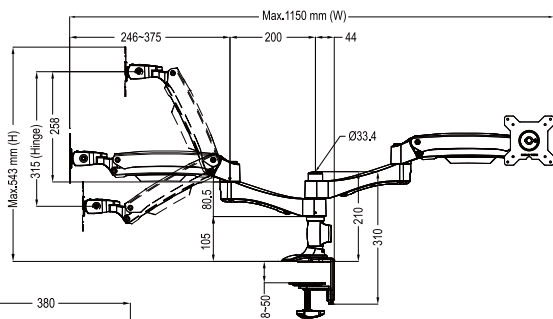

Enclosed Parts

COMMON PARTS

<p>A</p> 	<p>H</p>  <p>5mm</p>	<p>K</p> 
<p>B</p> 	<p>I</p> 	<p>L</p>  <p>2.5mm</p>
<p>F</p> 	<p>J</p> 	<p>M</p> 
<p>Parts for ARM11SC</p> <p>O</p>  <p>W</p>  <p>Y</p> 		<p>Parts for ARM22SC</p> <p>P</p>  <p>X</p>  <p>Y</p> 

Installation Guide

ARM11SC

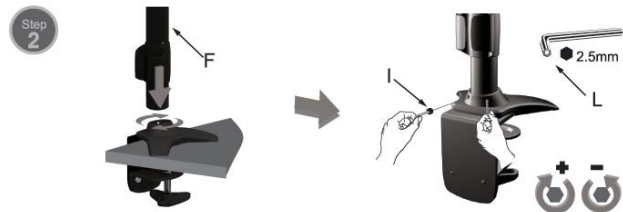
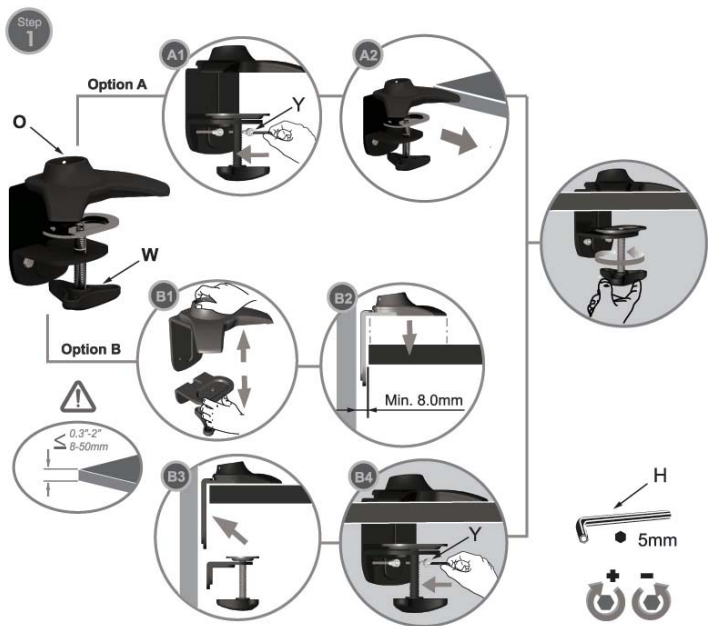

Step 3

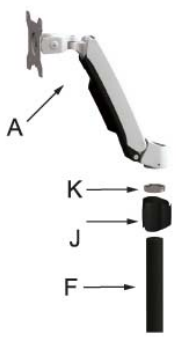

Step 3-2



Step 3



Step 3-2

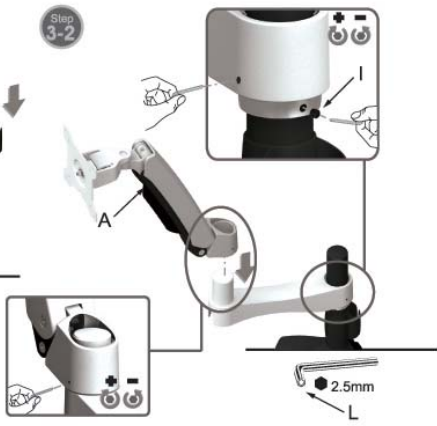

Step 4



Notice



Installation Guide

ARM22SC

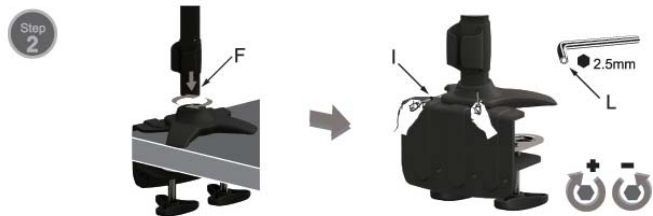
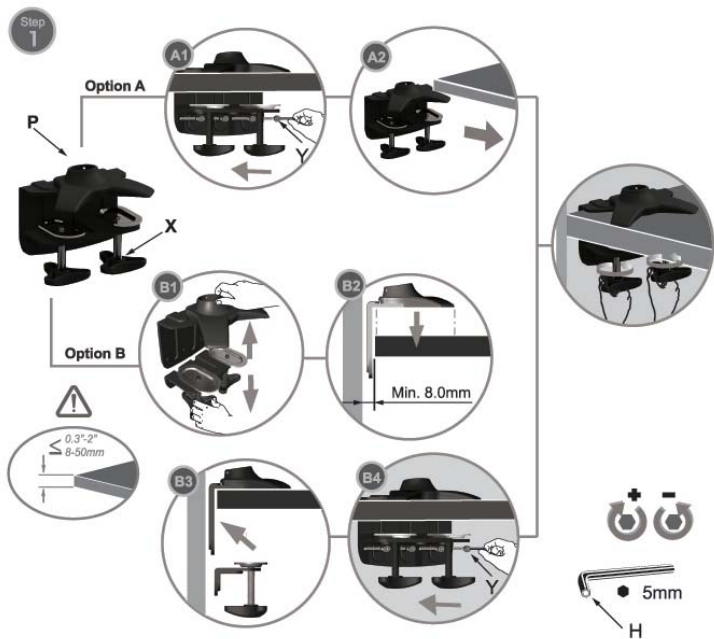

Step 3



Step 3-2

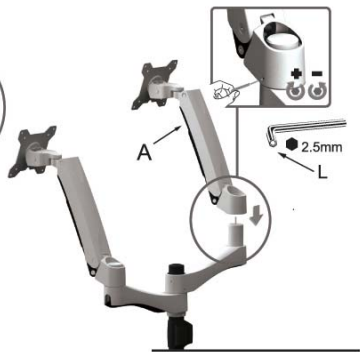

Step 4



Lift-up & down

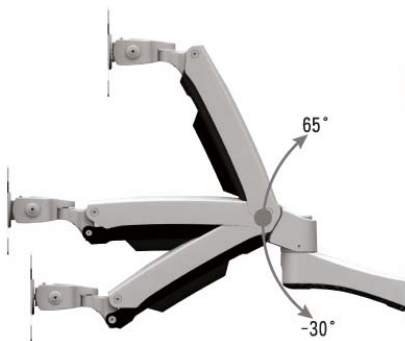

Torque Adjust

Lift - up & down (for ARM itself)
Torque Adjust

1. Tension of spring can be adjusted per user's preference.
2. **DO NOT OVERTIGHTEN** the Fastener. Over tightening the fastener may result your LCD ARM in damage.



Tilt-Backward & Forward

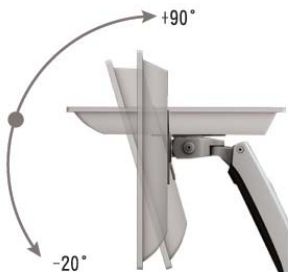

Torque Adjust

Tilt - Backward & Forward

Torque Adjust

1. Tension of Tilt can be adjusted so to match the right monitor or display unit weight.
2. **DO NOT OVERTIGHTEN** the Fastener. Over tightening the fastener may result damage on your equipment.



Arm Swing Adjust

Swivel & Rotate (Pivot)

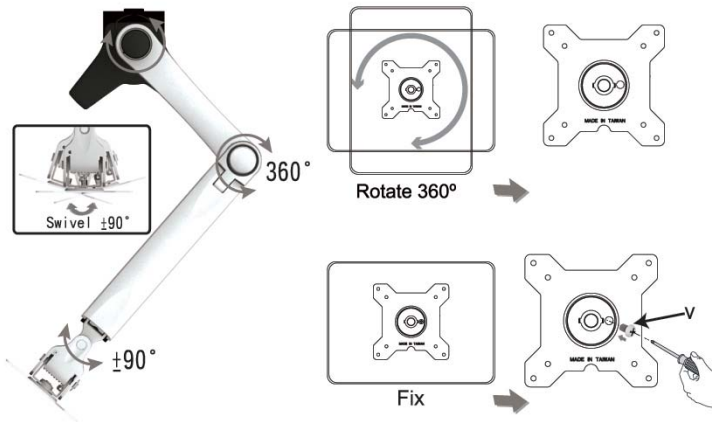

Cable Management

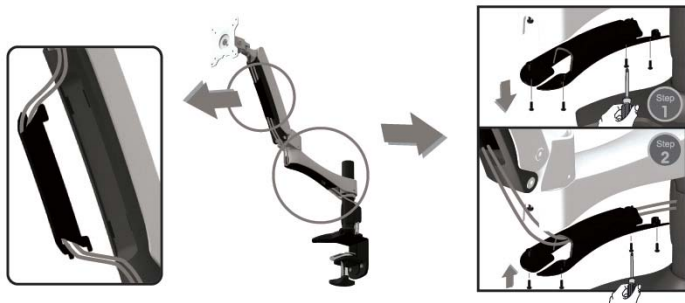

Caution

ENGLISH

1. To ensure safety, please read this manual carefully before installation and follow the instructions herein. Store this manual in a secure place for future reference.
2. The manufacturer shall not be legally responsible for any equipment damage or personnel injury caused by incorrect installation or operation other than that covered in this manual.
3. The subject product is designed for easy installation and removal. The manufacturer shall not be liable for damage to equipment or personnel injuries arising out of human factors or acts of God, such as earthquake or typhoon.
4. It is recommended that the subject product be installed by qualified personnel only.
5. At least two persons are needed to install or remove the product to avoid hazard of falling objects.
6. Only install on horizontal desks and avoid slanted desk surfaces.
7. To ensure safe installation, first check the structure of the desk and select a secure mounting location.
8. The desk should be strong enough to sustain a weight of at least four times of the display and the subject product combined. The mounting location must be able to withstand earthquake or other strong shock.
9. Do not modify any accessories or use broken parts. Contact your dealer with any questions.
10. Tighten all screws (do not exert excessive force to avoid breaking the screw or damaging its thread).
11. Since the manufacturer has no way to control the desk type and installation of this product, the warranty of the product shall only cover the body of the product. The warranty period of the product is 3 years.
12. Please consult the English language manual for any dispute on conditions.

DEUTSCH

1. Lesen Sie bitte vor der Installation das Handbuch sorgfältig durch und befolgen alle Anweisungen, um die Sicherheit zu gewährleisten. Heben Sie das Handbuch auf, damit Sie später darin nachlesen können.
2. Der Hersteller haftet für keine Geräte- oder Personenschäden, die durch unsachgemäße Installation oder Bedienung, die nicht in diesem Handbuch beschrieben ist, entstanden sind.
3. Die Tischhalterung ist für eine einfache Installation und Demontage ausgelegt. Der Hersteller haftet nicht für Geräte- oder Personenschäden, die durch menschliche Faktoren oder höhere Gewalt wie z.B. Erdbeben oder Orkan entstanden sind.
4. Wir empfehlen Ihnen die Tischhalterung nur von einem qualifizierten Techniker installieren zu lassen.
5. Die Installation oder Demontage des Produkts muss von mindestens zwei Personen ausgeführt werden, um die Gefahr, dass Gegenstände herunterfallen, zu vermeiden.
6. Montieren Sie das Produkt nur an einen horizontalen Tisch. Vermeiden Sie schräge Oberflächen.
7. Um die Sicherheit zu gewährleisten und Unfälle zu vermeiden, ist es notwendig, vor der Installation die Tischplatte auf Schäden zu überprüfen und eine unbeschädigte Stelle auszuwählen.
8. Der Tisch muss stark genug sein, um ein Gewicht von mindestens dem Vierfachen des Gesamtgewichts des Anzeigerätes und des Montagesets zu tragen. Der Montageort muss in der Lage sein, Erdbeben oder sonstige starke Erschütterungen standzuhalten.
9. Modifizieren Sie keine Zubehörteile. Verwenden Sie keine beschädigten Teile. Wenden Sie sich an Ihren Händler, wenn Sie Fragen haben.
10. Ziehen Sie alle Schrauben fest. (Wenden Sie nicht zu viel Kraft an, um ein Brechen der Schraube oder Beschädigen des Gewindes zu vermeiden.)
11. Der Hersteller hat keinen Einfluss auf den Tischtyp und die Installation der Tischhalterung. Deshalb deckt die Garantie des Produkts nur das Tischmontageset selbst ab. Die Garantie des Produkts gilt für 3 Jahre.
12. Bitte ziehen Sie die englische Version des Handbuchs zur Rate, falls es Unstimmigkeiten hinsichtlich der Bedingungen gibt.

FRANÇAIS

1. Afin d'assurer votre sécurité, nous vous prions de bien lire le manuel avant l'installation et de suivre attentivement les instructions qui y sont incluses. Conservez ce manuel dans un endroit sûr comme référence.
2. Le fabricant ne sera tenu également responsable d'aucun dommage à l'équipement ou de blessure corporelle causés par une mauvaise installation ou utilisation de l'équipement autre que celle décrite au sein du présent manuel.
3. Le produit est conçu de façon à faciliter l'installation et le déplacement. Le fabricant ne sera tenu responsable d'aucun dommage à l'équipement ou de blessure corporelle découlant d'erreur humaine ou de cas de force majeure, tels un tremblement de terre ou un typhon.
4. Il est recommandé de ne permettre qu'au personnel qualifié d'installer le produit.
5. L'installation ou le déplacement du produit doit être accompli par un minimum de deux personnes afin d'éviter les dangers potentiels causés par une chute.
6. Installez que sur les bureaux horizontaux et évitez les surfaces inclinées.
7. Afin d'assurer la sécurité et la prévention des accidents, il est impératif de vérifier la structure des bureaux et de choisir un endroit solide avant de l'installer.
8. Le bureau devrait être assez suffisamment fort pour soutenir un poids quatre fois supérieur à celui du poids combine de l'écran et du produit ensemble. L'emplacement du montage doit pouvoir survivre à un tremblement de terre ou autre choc intense.
9. Ne pas modifier les accessoires ou utiliser des parties cassées. Contacter votre distributeur pour toute question.
10. Resserrez toutes les vis (n'utilisez pas de force excessive pour éviter d'abîmer les vis ou le filetage).
11. Puisque le fabricant ne peut en aucun cas contrôler le type de bureau et la qualité de l'installation du produit, la garantie du produit ne couvre que le produit. La durée de la garantie du produit est de 3 ans.
12. Veuillez consulter le manuel Anglais pour tout disaccord quant aux termes.

Caution

ESPAÑOL

1. Para garantizar su seguridad, lea este manual detenidamente antes de la instalación y siga sus instrucciones. Conserve este manual en un lugar seguro para futuras consultas.
2. El fabricante no será legalmente responsable de ningún daño producido sobre el equipo o lesión personal causada por una instalación o uso no mencionado explícitamente en este manual.
3. El dicho producto ha sido diseñado para instalar y retirar fácilmente el dispositivo. El fabricante no se hace responsable de los daños provocados sobre el equipo o las lesiones personales que se deriven de factores humanos o actos de fuerza mayor, como un terremoto o un tifón.
4. Se recomienda que este producto sea instalado por personal cualificado.
5. Para evitar que se caiga el producto, la instalación o retirada deberá ser realizada por al menos dos personas.
6. Instale el producto en una mesa horizontal. Evite las superficies sesgadas.
7. Para garantizar su seguridad y evitar accidentes, compruebe la estructura de la mesa y seleccione un emplazamiento seguro antes de la instalación.
8. La mesa debe tener fuerza suficiente para soportar un peso de al menos cuatro veces la pantalla y el soporte en conjunto. El lugar de montaje debe ser capaz de aguantar terremotos u otros golpes fuertes.
9. No modifique ningún accesorio ni utilice componentes deteriorados. Póngase en contacto con su distribuidor si tiene alguna duda.
10. Apriete todos los tornillos (no ejerza demasiada fuerza para evitar que se roma el tornillo o se dañe la rosca).
11. Dado que el fabricante no dispone de ningún método para comprobar el tipo de mesa e instalación del dicho producto, la garantía del producto cubre únicamente el dicho producto en sí. El periodo de garantía de este producto es de 3 años.
12. Consulte el manual en inglés si tiene alguna duda acerca de las condiciones.

ITALIANO

1. Per garantire la sicurezza, leggere attentamente questo manuale prima di effettuare l'installazione e seguire le istruzioni qui contenute. Conservare questo manuale in un luogo sicuro per riferimenti futuri.
2. Il produttore non deve essere ritenuto responsabile legalmente per qualsiasi danno all'apparecchio o lesione alla persona provocati da installazione non corretta o funzionamento diverso da quello riportato nel seguente manuale.
3. Il prodotto è stato ideato per una facile installazione e rimozione. Il produttore non sarà responsabile per danni all'apparecchio o per lesioni alla persona derivanti da fattori umani o eventi naturali, come tifoni o terremoti.
4. Si consiglia di far installare la staffa per il prodotto solo da personale qualificato.
5. Per installare o rimuovere il prodotto sono necessarie almeno due persone per evitare rischi o la caduta di oggetti.
6. Installare solo su tavola orizzontale, evitare superfici inclinate.
7. Per garantire la sicurezza e per prevenire incidenti, è necessario, prima di eseguire l'installazione, controllare la struttura della tavola e scegliere un posizionamento sicuro.
8. La tavola deve essere abbastanza forte per sostenere almeno quattro volte il peso del monitor e della staffa per il montaggio insieme. Il punto di montaggio deve essere in grado di sopportare terremoti o urti forti.
9. Non modificare gli accessori o utilizzare parti rotte. Contattare il rivenditore per qualsiasi domanda.
10. Stringere tutte le viti (non applicare forza eccessiva per evitare la rottura delle viti o il danneggiamento della filettatura).
11. Dato che il produttore non ha alcun modo di controllare il tipo di tavola e l'installazione, la garanzia del prodotto coprirà esclusivamente il corpo della struttura per il prodotto. Il periodo di garanzia del prodotto è di tre anni.
12. Consultare il manuale in lingua inglese per eventuali controversie sulle condizioni.

РУССКИЙ

1. Для обеспечения безопасности внимательно прочтите данное руководство перед установкой и следуйте его инструкциям. Держите данное руководство в доступном месте для того, чтобы в случае необходимости быстро получить справку.
2. Производитель не несет юридической ответственности за повреждение оборудования или травмы, вызванные неправильной установкой или управлением, несоответствующим данному руководству.
3. Конструкция кронштейна разработана с целью облегчения установки и демонтажа. Производитель не несет ответственности за повреждение оборудования и людей вследствие наступления форс-мажорных обстоятельств, таких как землетрясение или тайфун.
4. Рекомендуем производить установку данного кронштейна силами квалифицированного персонала.
5. Для установки или удаления продукта требуется как минимум 2 человека во избежание опасности от падающих предметов.
6. Устанавливайте только на горизонтальной поверхности, избегайте наклонных поверхностей.
7. Для обеспечения надежного крепления сначала проверьте структуру стены и выберите безопасное место для крепления.
8. Стена должна быть достаточно прочной, чтобы выдержать нагрузку вчетверо превышающую вес дисплея вместе с кронштейном. Место для установки должно выдерживать землетрясение или прочие сильные нагрузки.
9. Не изменяйте любые аксессуары и не используйте поврежденные элементы. В случае вопросов обращайтесь к дилеру.
10. Затяните все винты (но не прилагайте излишних усилий, чтобы не сломать винт или не повредить его резьбу).
11. Поскольку производитель не может проконтролировать тип стены и правильность установки, гарантийный обязательства распространяются только на сам кронштейн. Период действия гарантии на кронштейн составляет 3 лет.
12. В случае сомнений в отношении условий см. версию руководства на английском языке.

Caution

繁體中文

1. 為確保安全，在安裝前，請先詳細閱讀本安裝說明書並遵守內容，妥善保存本安裝說明書於安全的地方，以便日後參考。
2. 因錯誤的安裝及操作方法所造成的設備毀損及人員傷害，本製造商將完全不承擔所衍生的相關法律責任。
3. 本產品之設計為容易安裝及拆卸，若因人為或天然災害：如地震、颱風…等，所造成之設備損毀及人員傷害，本製造商將完全不承擔所衍生的相關法律問題。
4. 安裝面板顯示器及本產品需由專業人員執行安裝。
5. 無論安裝或移除本產品，至少需由2人執行，以避免沈重的物品掉落造成人員傷害或物品損毀。
6. 只能安裝於水平的桌面，避免傾斜的牆面。
7. 為了安全及防止意外發生，安裝前，需檢查桌面的結構及選擇耐久性高的適當位置。
8. 桌面需能支撐面板顯示器及壁掛架總重量4倍以上，且需確保有足夠的強度能承受地震及其它外力的振動。
9. 請勿自行變更任何零件，勿使用已破損的零件，若有任何問題請與你的經銷商聯絡。
10. 鎖緊螺絲(切勿以過大的扭力鎖付螺絲，以免造成螺絲斷裂或螺牙的損害)。
11. 因桌面種類及安裝施工品質非本製造商所能控制，本產品所保固範圍只限產品本身，本產品保固期限3年。
12. 若有任何條文爭議，請以英文說明書為主。

簡體中文

1. 為確保安全，在安裝前，請先詳細閱讀本安裝說明書並遵守內容，妥善保存本安裝說明書於安全的地方，以便日後參考。
2. 因錯誤的安裝及操作方法所造成的設備毀損及人員傷害，本製造商將完全不承擔所衍生的相關法律責任。
3. 本產品之設計為容易安裝及拆卸，若因人為或天然災害：如地震、台風…等，所造成之設備損毀及人員傷害，本製造商將完全不承擔所衍生的相關法律問題。
4. 安裝面板顯示器及本產品需由專業人員執行安裝。
5. 無論安裝或移除本產品，至少需由2人執行，以避免沉重的物品掉落造成人員傷害或物品損毀。
6. 只能安裝於水平的桌面，避免傾斜的牆面。
7. 為了安全及防止意外發生，安裝前，需檢查桌面的結構及選擇耐久性高的適當位置。
8. 桌面需能支撐面板顯示器及壁掛架總重量4倍以上，且需確保有足夠的強度能承受地震及其它外力的振動。
9. 請勿自行變更任何零件，勿使用已破損的零件，若有任何問題請與你的經銷商聯絡。
10. 鎖緊螺絲(切勿以過大的扭力鎖付螺絲，以免造成螺絲斷裂或螺牙的損害)。
11. 因桌面種類及安裝施工品質非本製造商所能控制，本產品所保固範圍只限產品本身，本產品保固期限3年。
12. 若有任何條文爭議，請以英文說明書為主。

日本語

1. 安全にご使用いただく為に、設置前に本マニュアルに記載された手順をよくご確認ください。本マニュアルはいつでも参照できるように大切に保管してください。
2. 不適切な取り付け/取り扱により発生した設備の損害及び人員の傷害に対しては、当社は一切の法的責任を負いません。
3. 本製品は取り付け及び取り外しが容易に出来るよう設計されております。人為的或は地震・台風などの自然災害によって発生した設備の損害及び人員の傷害に対しては、当社は一切の法的責任を負いません。
4. 本製品の取り付けは必ず専門の業者に依頼してください。
5. 重い物品の落下による人員或は物品の損傷を避ける為、本製品の取り付け/取り外しは少なくとも二人で行う必要があります。
6. 水平な場所のみに取り付けし、傾斜面への取り付けは避ける。
7. 安全を確保し、いかなる事故も避ける為、据置場所(例：机、台)の構造を確認し、耐久性のじゅうぶんな場所を選択すること。
8. 据置面にはディスプレイパネル及び壁掛けブラケットの総重量の4倍以上を支持でき、且つ地震及び外部からの振動に耐える強度を確保することが必要です。
9. ご自分で部品を変更したり破損した部品を使用しないでください。問題が有る時は、お買い求めになった販売店に問合せください。
10. ネジを締め付けてください(ネジの破断やネジ山の損害を生じない為に、過大なトルクでネジを締め付けしないでください)。
11. 据置台の種類及び設置方法は当社の責任範囲ではないので、本製品の保証範囲は、正しく組み立てられたことを前提に、製品本体のみに限り、本製品の保証期限は3年とします。
12. 各項目文章に問題がある時は、英文説明を参照ください。

Caution

한 국 어

1. 안전을 보장하기 위해 설치 전 이 매뉴얼을 신중히 읽어 보고 지침서에 따르십시오. 추후 참고를 위해 이 매뉴얼을 안전한 장소에 저장하십시오.
2. 제조업자는 이 매뉴얼에서 다루고 있는 부분 이외의 부정확한 설치 혹은 작동으로 야기되는 어떤 장비 손상 혹은 개인 상해에 법적으로 책임을 지지 않습니다.
3. 본 제품은 설치 및 제거가 쉽게 설계되어 있습니다. 제조업자는 지진 혹은 태풍과 같은 불가항력적 천재지변 혹은 인간의 관리 한계를 벗어난 사고로 야기되는 인적 상해 혹은 장비 손상에 책임을 지지 않습니다.
4. 본 제품은 설치 전문가 설치하도록 권장합니다.
5. 물체가 떨어지는 위험을 방지하기 위해 두 사람 이상이 제품을 설치하거나 제거해야 합니다.
6. 수평면에만 설치하고 경사면은 피하십시오.
7. 안전한 설치를 위해 먼저 책상의 구조를 체크하고 안정된 설치 위치를 선택해야 합니다.
8. 책상은 디스플레이와 본 제품을 향한 중량의 최소 4배 이상을 지탱할 수 있어야 합니다. 설치하는 위치는 지진 혹은 기타 강한 충격에 반드시 견딜 수 있어야 합니다.
9. 부속품을 변경하거나 깨진 부품을 사용하지 마십시오. 질문 사항은 판매업자와 연락하십시오.
10. 나사를 모두 죄입니다 (나사를 부수거나 나삿니를 손상시키지 않기 위해 과도한 힘을 가하지 마십시오).
11. 제조업자는 책상의 유형이나 본 제품의 설치에 대해 관리 및 제어를 할 수 없기 때문에 제품의 보증은 본 제품 본체에만 적용합니다. 제품의 보증 기간은 3년입니다.
12. 조건에 대한 논쟁이 있을 경우에는 영어 매뉴얼을 참고하십시오.

Warning

ENGLISH

Various displays have different screw hole specifications. Please check that the Screws(M) fits the specifications for the display to be mounted. Please contact your dealer with any questions.

DEUTSCH

Die Spezifikationen der Befestigungslöcher verschiedener Anzeigergeräte sind unterschiedlich. Bitte prüfen Sie, ob die Schrauben (L) den Spezifikationen Ihres Anzeigergerätes entsprechen. Bitte wenden Sie sich an Ihren Händler, wenn Sie Fragen haben.

FRANÇAIS

Des écrans différents possèdent des caractéristiques différentes pour les trous de vis. Veuillez vérifier que les vis (M) correspondent bien au modèle de l'écran que vous voulez installer. Contactez votre revendeur si vous avez des questions.

ESPAÑOL

Las distintas pantallas poseen diferentes orificios. Compruebe que los tornillos (M) sean adecuados para la pantalla a montar. Póngase en contacto con su distribuidor si tiene alguna duda.

ITALIANO

Diversi monitor hanno diverse specifiche riguardanti i fori per le viti. Controllare che le viti (M) siano adeguate alle specifiche del monitor da montare. Contattare il rivenditore per qualsiasi domanda.

РУССКИЙ

Различные индикации имеют по-разному спецификации отверстия винта. Пожалуйста проверите что винты (M) приспособливают спецификации для индикации, котор нужно установить. Пожалуйста свяжитесь ваш торговец с VСеми вопросами.

繁體中文

由於面板顯示器後殼壁掛螺絲孔規格不同，安裝前必須先確認本配件包所附的螺絲(M)規格及長度，是否適用你所要安裝的面板顯示器，若有問題請與你的經銷商聯絡。

簡體中文

由於面板顯示器後殼壁掛螺絲孔規格不同，安裝前必須先確認本配件包所附的螺絲(M)規格及長度，是否適用你所要安裝的面板顯示器，若有問題請與你的經銷商聯絡。

日 本 語

パネルディスプレイ背面ケースの壁掛けネジの規格は不同ですので、取付け前に必ず本部品梱包に入っているネジ(M)規格及び長さが取付けるパネルディスプレイに適用するか否かを確認してください。問題がある時は、お買い求めになった販売店に問合せください。

한 국 어

다양한 디스플레이에 따라 다른 나사 구멍이 지정됩니다. 해당 디스플레이를 장착하기 위한 명세에 나사(M)가 맞는지 확인하여 주십시오. 질문 사항은 판매업자와 연락하십시오.

Warranty Information

This product has a limited 3 year warranty in North America, Europe, and Australia.

For information on warranty periods in other regions, please contact your reseller or SilverStone authorized distributor.

Warranty terms & conditions

- Product component defects or damages resulted from defective production is covered under warranty.
Defects or damages with the following conditions will be fixed or replaced under SilverStone Technology's jurisdiction.
 - Usage in accordance with instructions provided in this manual, with no misuse, overuse, or other inappropriate actions.
 - Damage not caused by natural disaster (thunder, fire, earthquake, flood, salt, wind, insect, animals, etc...)
 - Product is not disassembled, modified, or fixed. Components not disassembled or replaced.
 - Warranty mark/stickers are not removed or broken.Loss or damages resulted from conditions other than ones listed above are not covered under warranty.
- Under warranty, SilverStone Technology's maximum liability is limited to the current market value for the product (depreciated value, excluding shipping, handling, and other fees). SilverStone Technology is not responsible for other damages or loss associated with the use of product.
- Under warranty, SilverStone Technology is obligated to repair or replace its defective products. Under no circumstances will SilverStone Technology be liable for damages in connection with the sale, purchase, or use including but not limited to loss of data, loss of business, loss of profits, loss of use of the product or incidental or consequential damage whether or not foreseeable and whether or not based on breach of warranty, contract or negligence, even if SilverStone Technology has been advised of the possibility of such damages.
- Warranty covers only the original purchaser through authorized SilverStone distributors and resellers and is not transferable to a second hand purchaser.
- You must provide sales receipt or invoice with clear indication of purchase date to determine warranty eligibility.
- If a problem develops during the warranty period, please contact your retailer/reseller/SilverStone authorized distributors or SilverStone <http://www.silverstonetek.com>.
Please note that: (i) You must provide proof of original purchase of the product by a dated itemized receipt; (ii) You shall bear the cost of shipping (or otherwise transporting) the product to SilverStone authorized distributors. SilverStone authorized distributors will bear the cost of shipping (or otherwise transporting) the product back to you after completing the warranty service; (iii) Before you send the product, you must be issued a Return Merchandise Authorization ("RMA") number from SilverStone. Updated warranty information will be posted on SilverStone's official website. Please visit <http://www.silverstonetek.com> for the latest updates.

Additional info & contacts

For North America (usasupport@silverstonetek.com)

SilverStone Technology in North America may repair or replace defective product with refurbished product that is not new but has been functionally tested. Replacement product will be warranted for remainder of the warranty period or thirty days, whichever is longer. All products should be sent back to the place of purchase if it is within 30 days of purchase, after 30 days, customers need to initiate RMA procedure with SilverStone Technology in USA by first downloading the "USA RMA form for end-users" form from the below link and follow its instructions.
<http://silverstonetek.com/contactus.php>

For Australia only (support@silverstonetek.com)

Our goods come with guarantees that cannot be excluded under the Australian Consumer Law. You are entitled to a replacement or refund for a major failure and for compensation for any other reasonably foreseeable loss or damage. You are also entitled to have the goods repaired or replaced if the goods fail to be of acceptable quality and the failure does not amount to a major failure. Please refer to above "Warranty terms & conditions" for further warranty details.

SilverStone Technology Co., Ltd, 12F No, 168 Jiankang Rd., Zhonghe Dist., New Taipei City 235 Taiwan R.O.C. + 886-2-8228-1238 (standard international call charges apply)

For Europe (support.eu@silverstonetek.de)

For all other regions (support@silverstonetek.com)

SilverStone Technology Co., Ltd.

www.silverstonetek.com

support@silverstonetek.com

Issue date: January, 2013

NO:G11218500