



by Schneider Electric

# Tower to Rack-Mount Conversion Guide Smart-UPS™ On-Line Rack SRTRK2

## Package Contents

Inspect the contents upon receipt. Notify the carrier and dealer if the unit is damaged.

### All Models

One Rail Kit with instructions and hardware for installing rails in a rack.

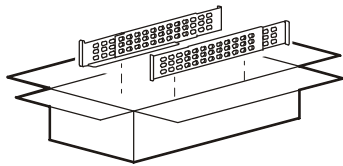

Two Rail cleats

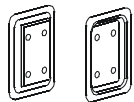

### SRT5K, 3U models and external battery packs

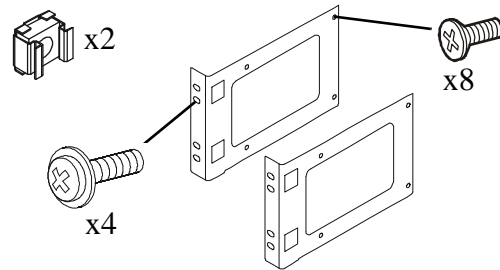

### SRT8K/SRT10K, 6U models

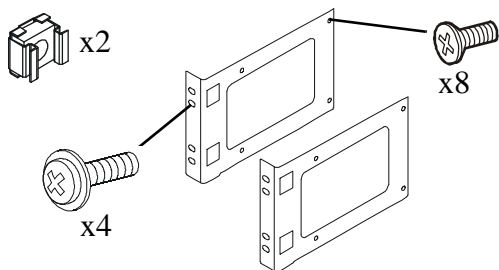
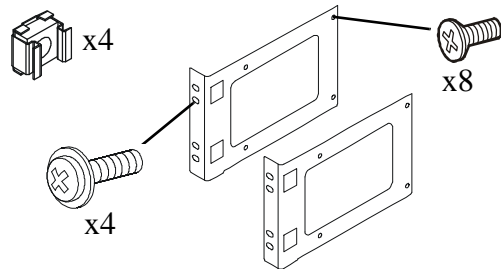

### SRT6K, 4U models

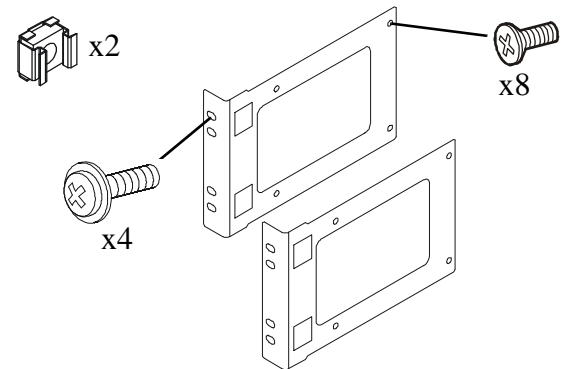

# Tower to Rack-Mount Conversion

## ⚠ CAUTION

### DAMAGE TO EQUIPMENT OR PERSONNEL

- The equipment is heavy. Each battery module weighs 17 kg (37 lb).
- Always practice safe lifting techniques adequate for the weight of the equipment.
- Remove the battery modules before installing the UPS.
- Use the battery module handle to carefully slide the battery module in or out of the unit.
- Do not use the battery module handle to lift or carry the battery module.

Failure to follow these instructions can result in equipment damage and minor or moderate injury.

## SRT5K/SRT6K UPS

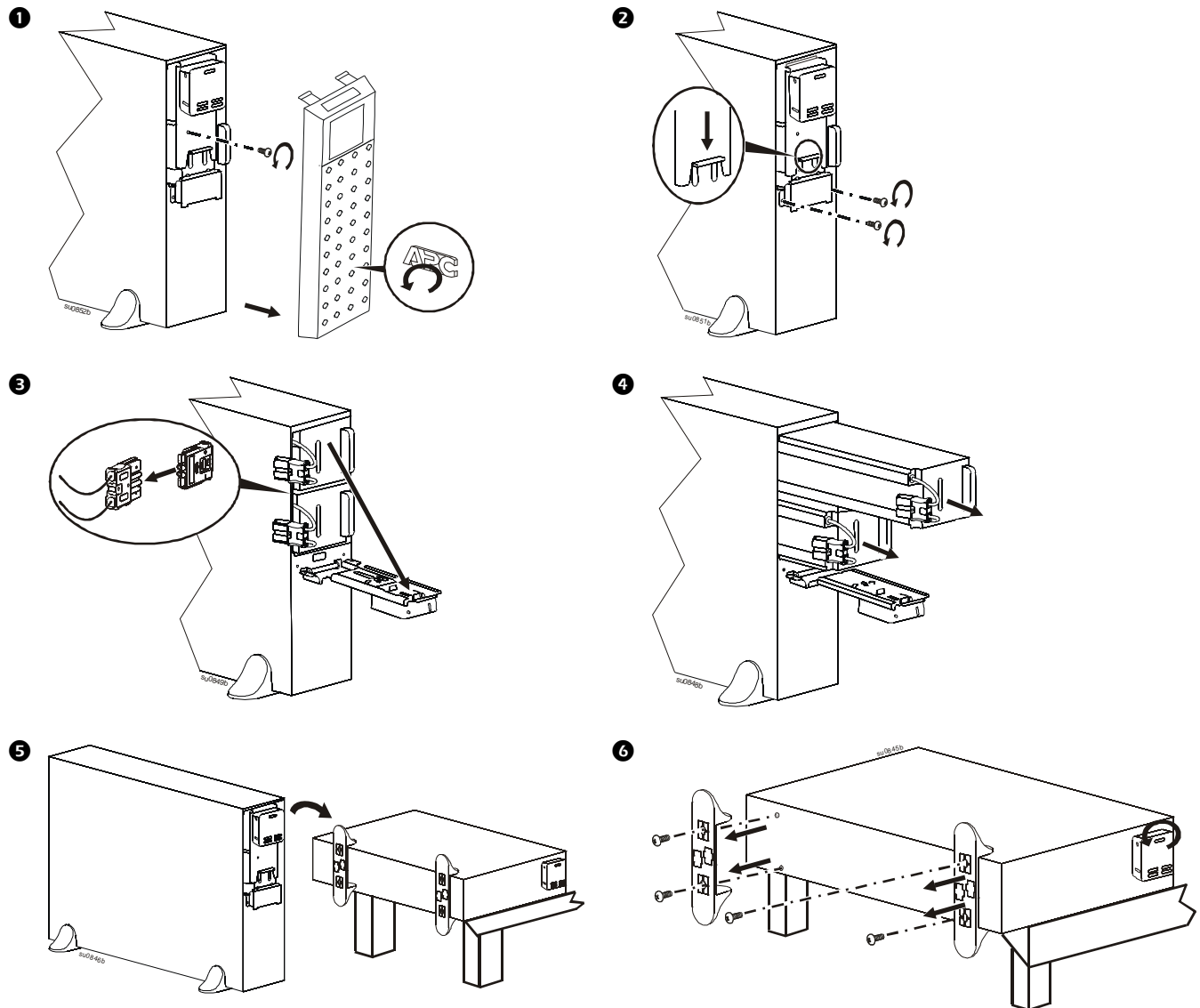

# Install the SRT5K/SRT6K in a rack

Refer to the rail kit Installation Guide for instructions on rail installation.

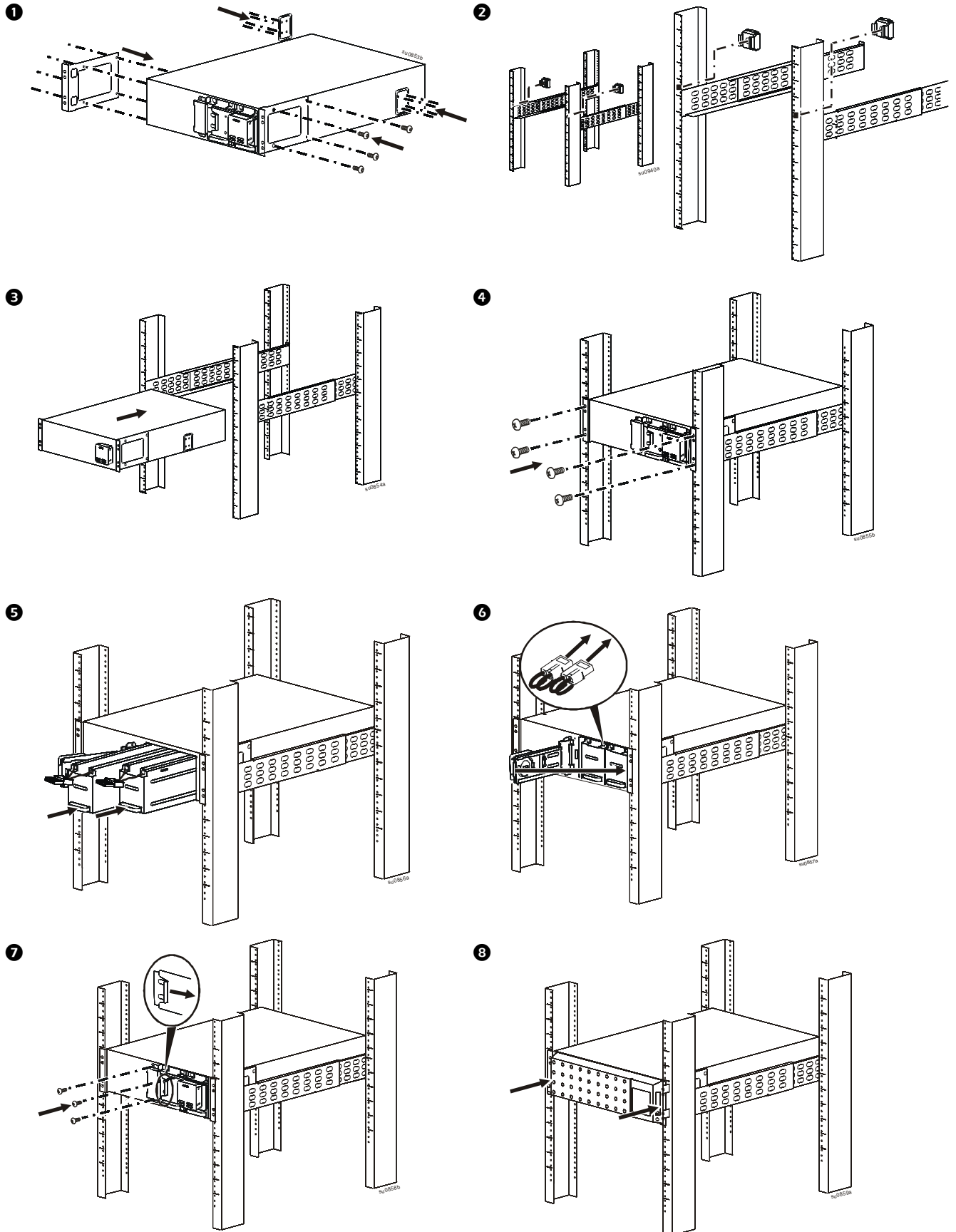

# SRT5K/SRT6K UPS with one external battery pack

1

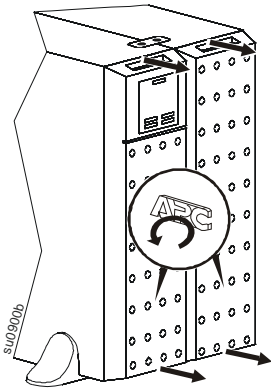

2

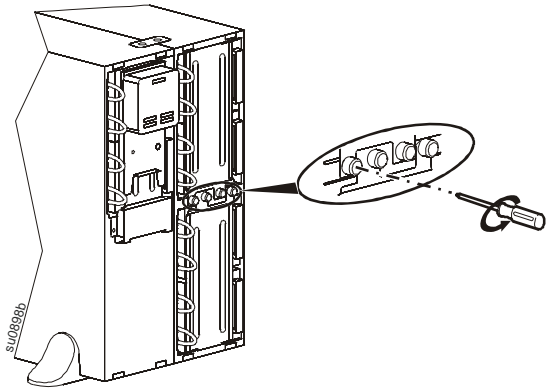

3

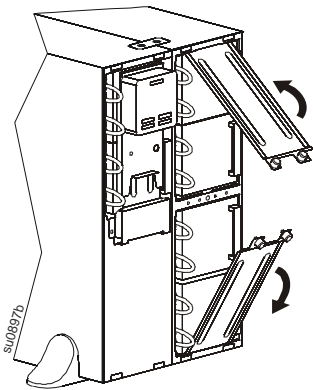

4

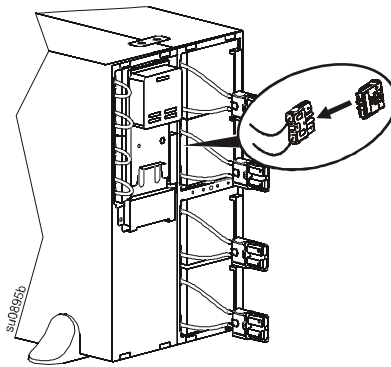

5

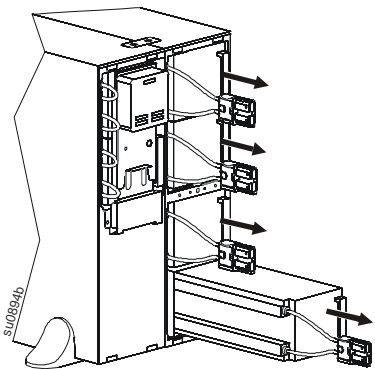

6

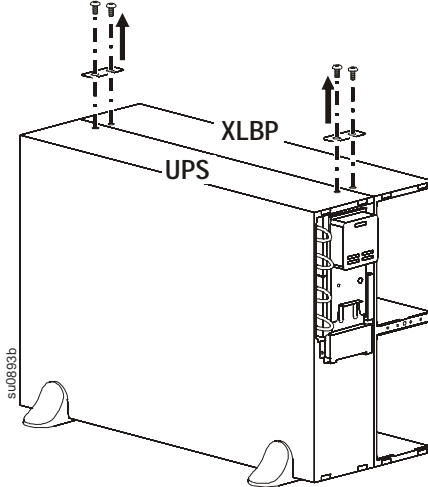

7

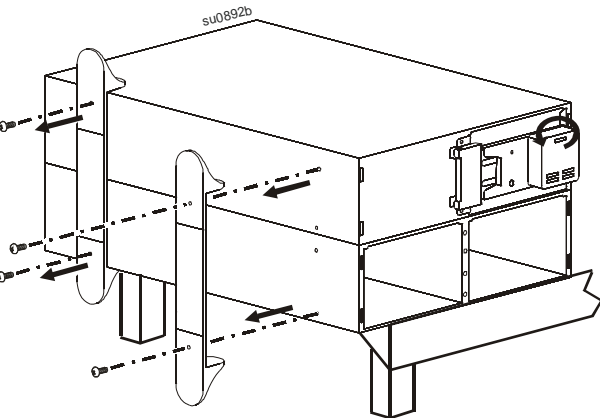

## Install the SRT5K/SRT6K with one external battery pack in a rack

The process for installation of an external battery pack with UPS models SRT8K/SRT10K models is identical to that described for the SRT5K/SRT6K models.

Refer to the rail kit Installation Guide for instructions on rail installation.

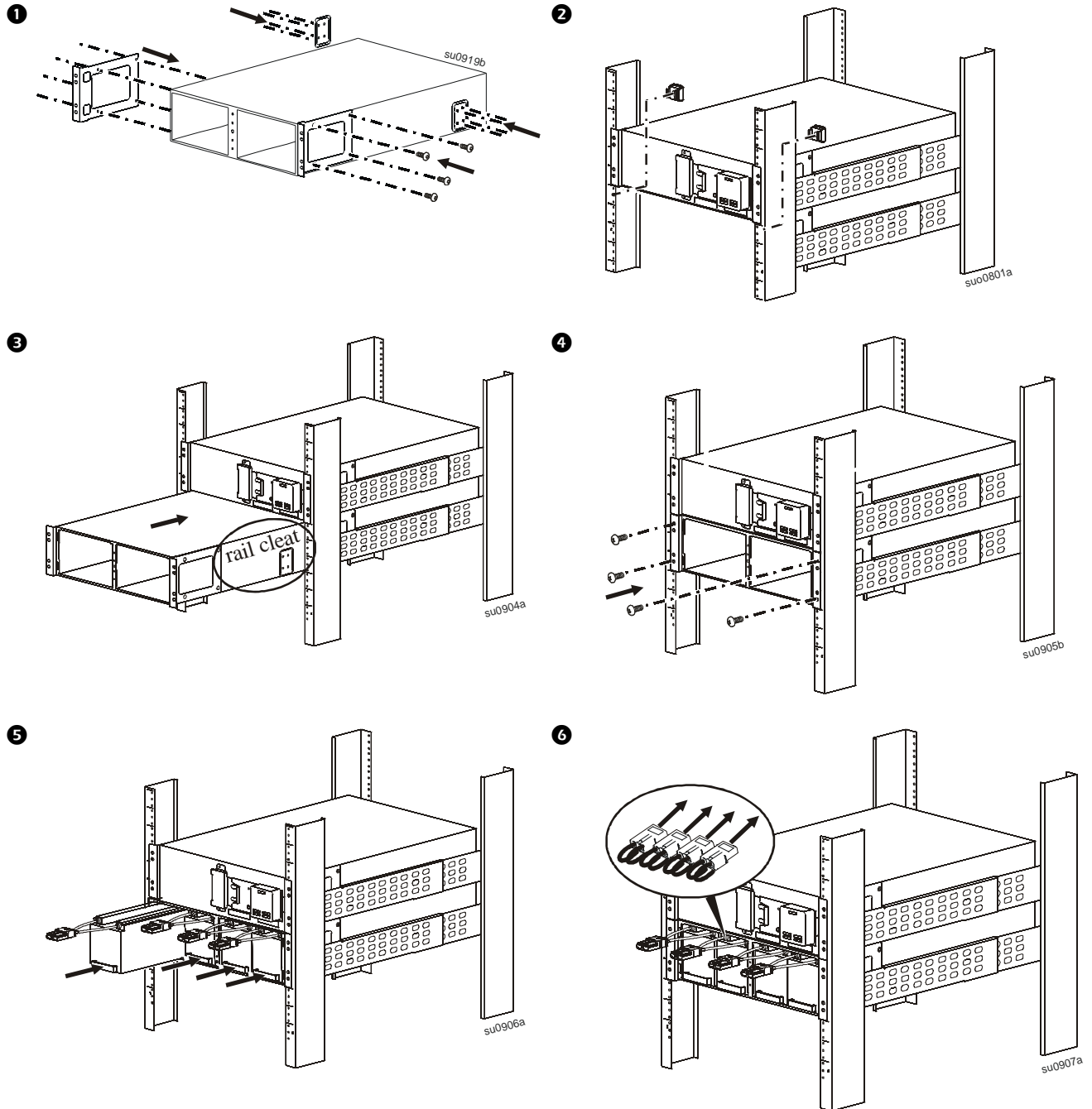

7

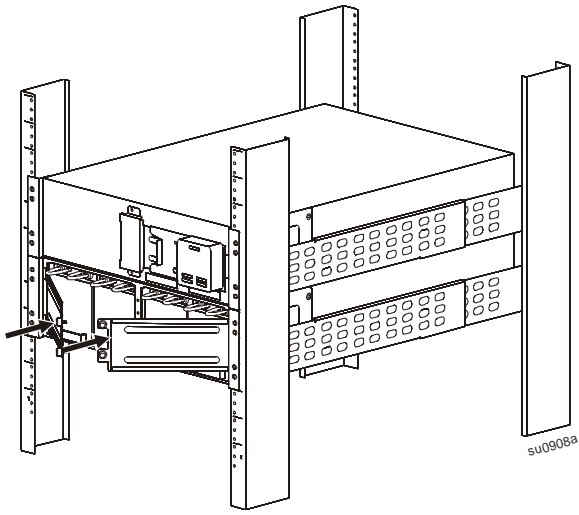

8

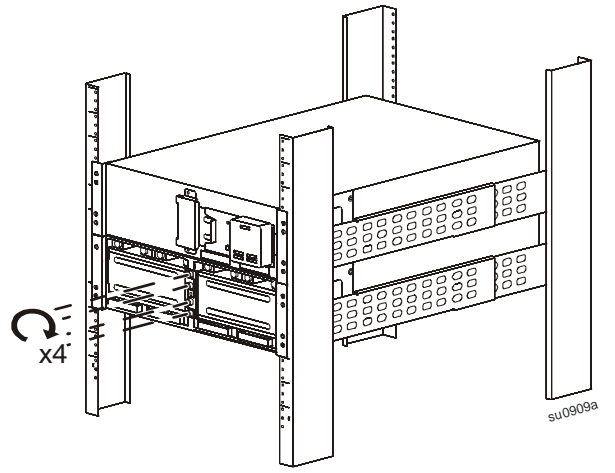

9

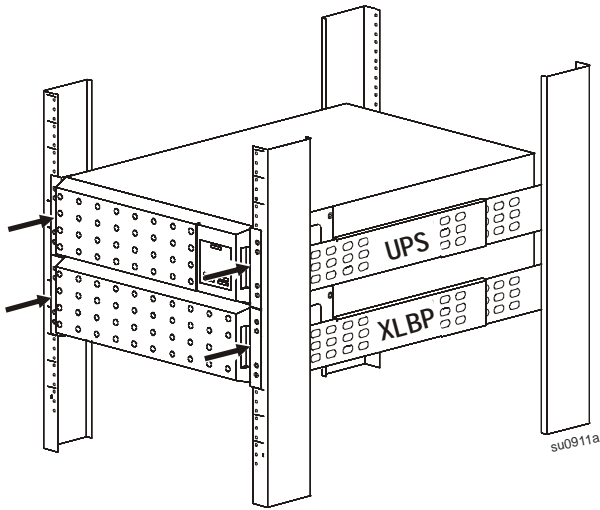

### SRT8K/SRT10K UPS

1

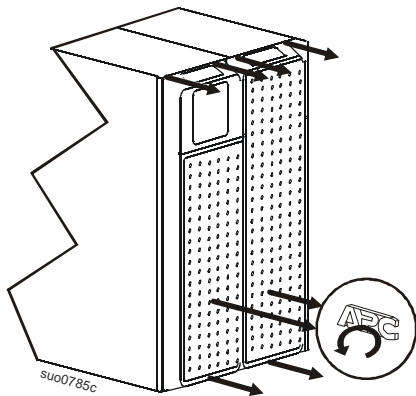

2

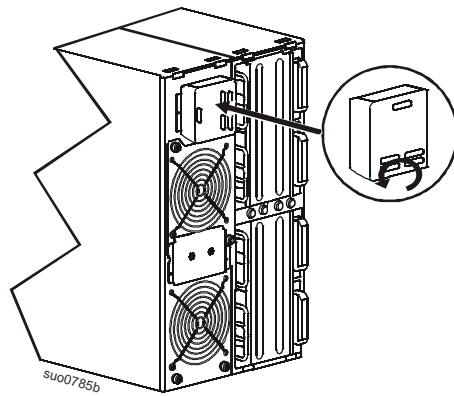

3

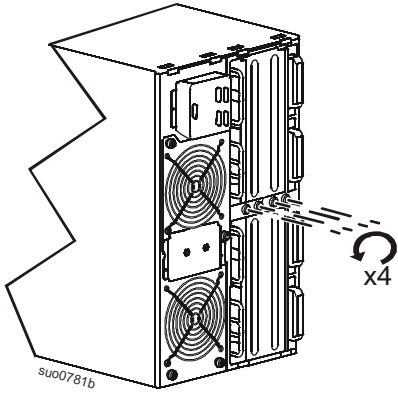

4

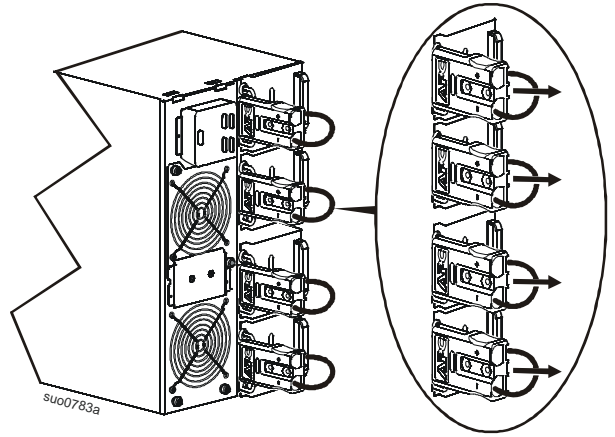

5

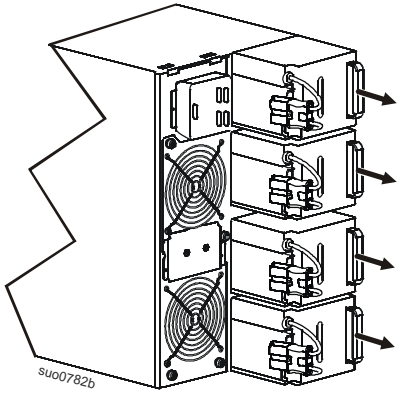

**Install SRT8K/SRT10K UPS in a rack**

Refer to the rail kit Installation Guide for instructions on rail installation.

1

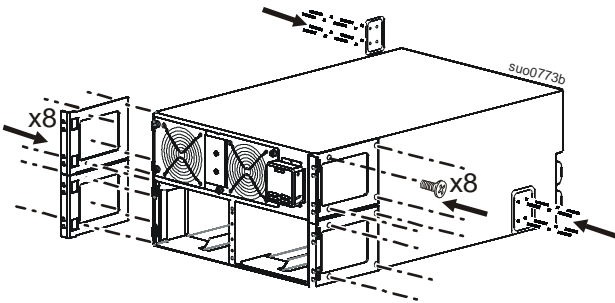

2

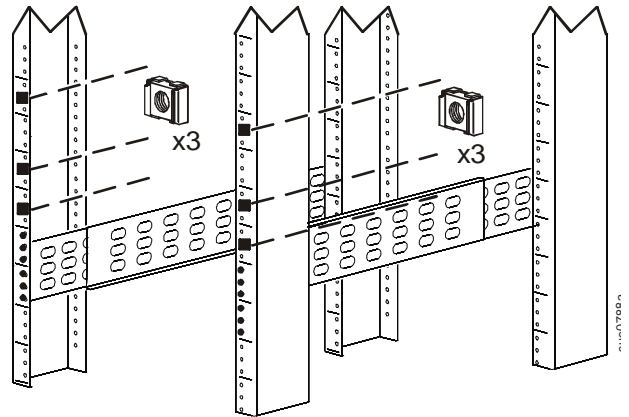

3

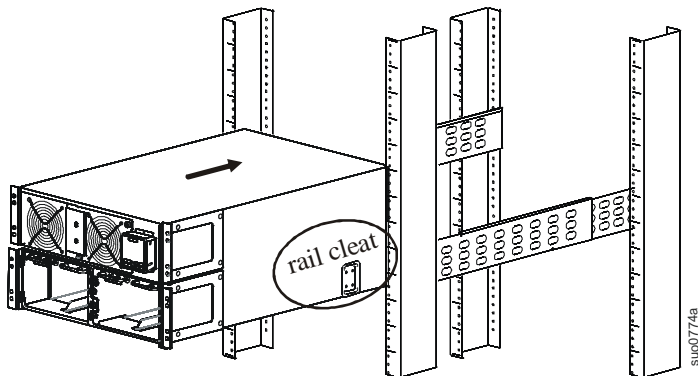

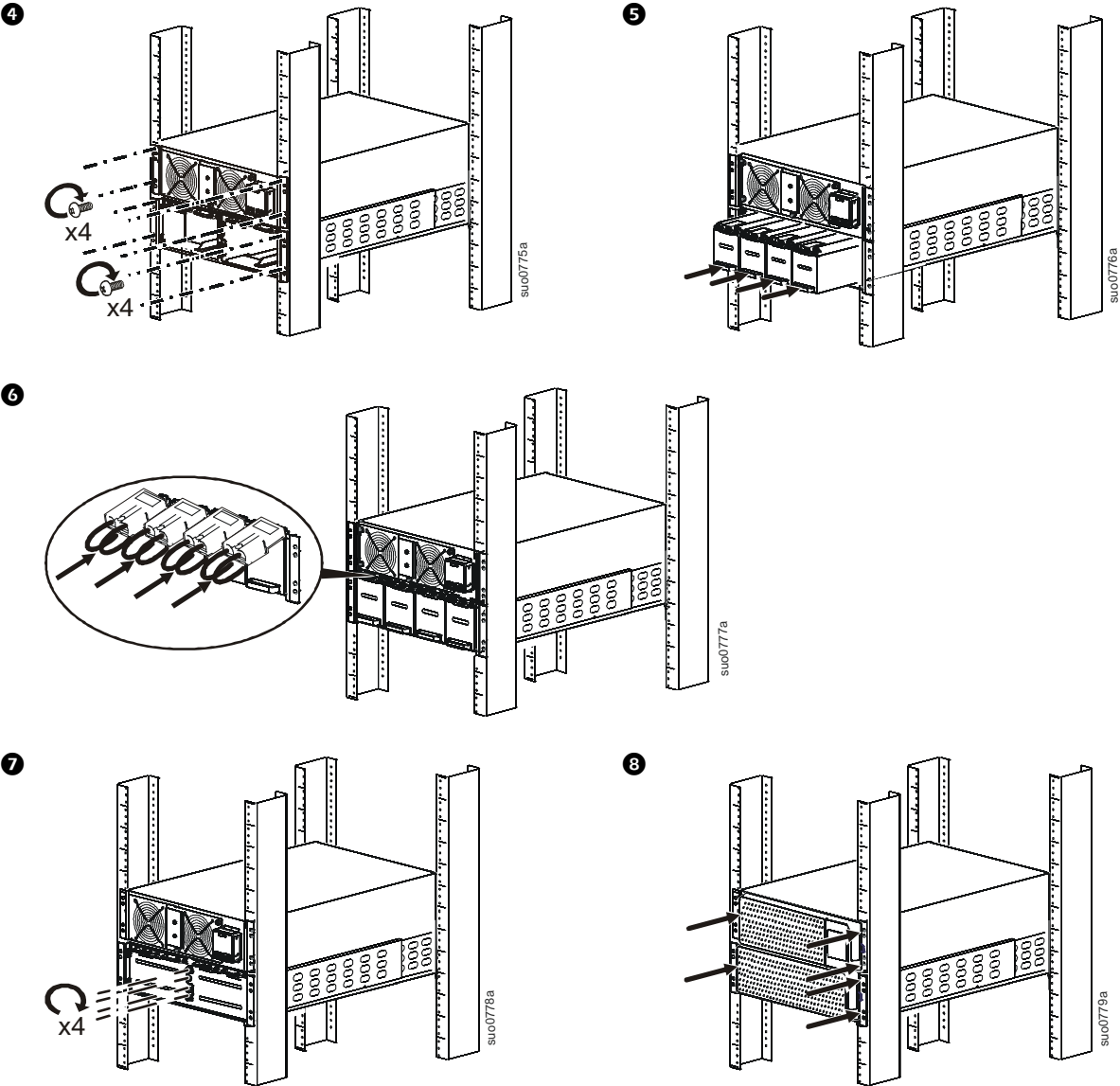

The process for installation of an external battery pack with UPS models SRT8K/SRT10K models is identical to that described for the SRT5K/SRT6K models.

Refer to the installation process described in the section, **Install the SRT5K/SRT6K with one external battery pack.**

Customer support and warranty information is available at the APC by Schneider Electric web site, [www.apc.com](http://www.apc.com).

© 2014 APC by Schneider Electric. APC, the APC logo, Smart-UPS and PowerChute are owned by Schneider Electric Industries S.A.S. or their affiliated companies. All other trademarks are property of their respective owners.

EN 990-5288  
2/2014