



USER'S MANUAL



ENTHOO PRIMO
ENTHOO SERIES

PHANTEKS
DESIGNED IN THE NETHERLANDS

INTRODUCTION

Congratulations on your purchase of the Phanteks Enthoo Series Case and welcome to the User's Guide. Phanteks believes that meaningful designs are created through the fusion of form and function.

Caution

Please take a moment to carefully go through the installation guide. Phanteks will not take responsibility for any damages incurred due to incorrect installation and incorrect usage of this product. Thank you.

ENTHOO PRIMO

The bar has been set to a new standard with Phanteks' release of their first Enthoo Series case. Passionate about cooling and the one that brought you the world's best air coolers, Phanteks enters the chassis arena with their functional design with exceptional cooling possibilities, the Enthoo Primo.

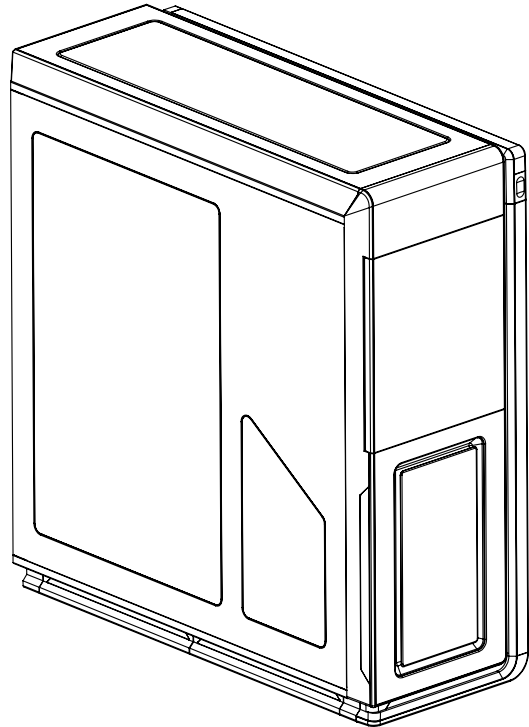

TABLE OF CONTENTS

1. SPECIFICATIONS	5
2. EXPLODED VIEW	6
3. ACCESSORIES	8
4. BRACKETS	9
5. I/O PORTS	10
6. CONNECTIONS	11
7. PANEL REMOVAL	13
8. MOTHERBOARD INSTALLATION	15
9. POWER SUPPLY INSTALLATION	17
10. FILTERS REMOVAL	19
11. FANS COMPATIBILITY	20
12. PWM HUB	21
13. SSD/ODD INSTALLATION	22
14. HARD DRIVE INSTALLATION	23
15. WATERCOOLING INSTALLATION	25
16. SERVICE AND SUPPORT	31

1. SPECIFICATIONS

CASE SPECIFICATIONS

Dimension	250 mm x 650 mm x 600 mm (W x H x D)
Form Factor	Full tower
Material(s)	Aluminum faceplates, Steel chassis
Motherboard support	ATX, EATX, mATX, SSI EEB
Weight	17.9 kg
Front I/O	2x USB 3.0, 2x USB 2.0, Mic, Headphone, LED ON/OFF switch, Power Reset
Side window	Yes, split-window design

EXPANSION & DRIVE BAYS

Expansion slots	8
Power supply slots	2
External 5.25"	5
Internal 3.5"	6 (2x 3HDD cages)
Internal 2.5"	12 (2x 3HDD cages + 2x doublestack SSD brackets) (*expandable to 3x)

COOLING

	120 mm fan	140 mm fan
Front	2x	2x (2x included with LED)
Top	4x	3x (1x included)
Side	2x	2x
Rear(top)	1x	1x (1x included)
Rear(bottom)	1x	1x
Bottom	4x	2x (1x included)
HDD	2x	-

LIQUID COOLING

	120 mm radiator	140 mm radiator
Front	Up to 240	-
Top	Up to 480	Up to 420
Side (w/out HDD cages)	Up to 240	-
Rear	120	140
Bottom	Up to 480	Up to 280

PH-F140SP (included fans)

Speed (rpm)	1200 ± 250 rpm
Max Airflow	82.1 CFM
Static Pressure	1.33mm H2O
Acoustical Noise	19 dB

CLEARANCE

Graphic card	257 mm (reservoir bracket installed) 277 mm (reservoir bracket installed w/o cover) 350 mm (no reservoir bracket) 390 mm (HDD cages in front position) 515 mm (no HDD cages)
CPU cooler	207 mm
Cable management	30 mm
Model number	PH-ES813P
Warranty	5 Years

2. EXPLODED VIEW

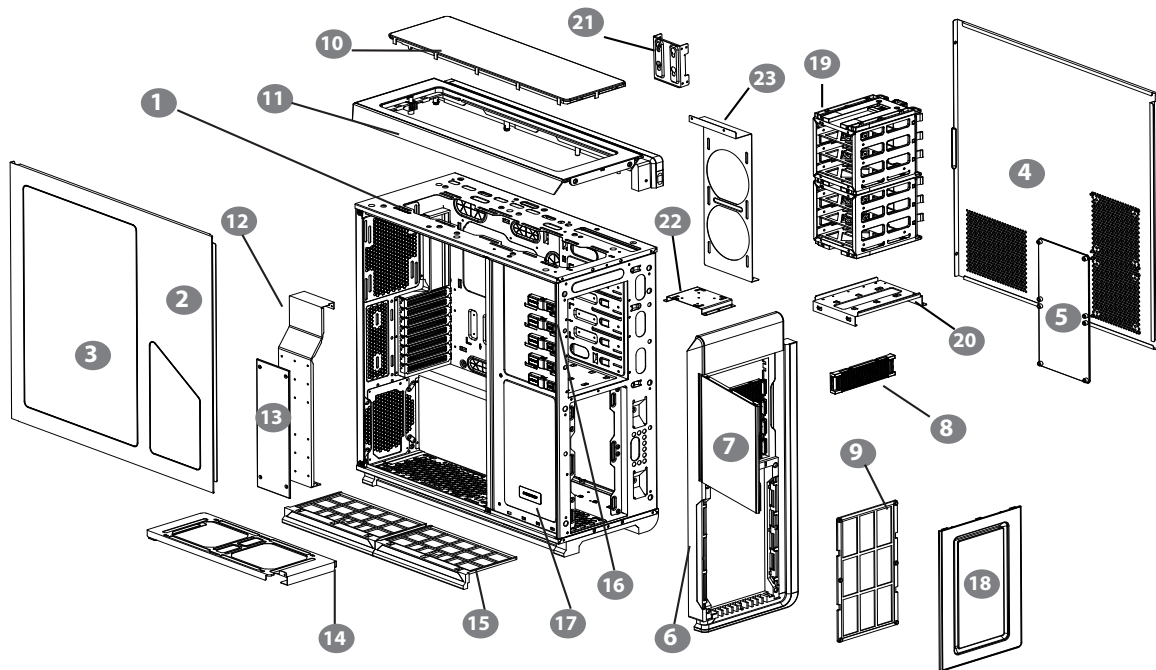

1. Chassis
2. Left Side Panel
3. Side Window
4. Right Side Panel
5. Right Side Mesh Cover
6. Front Panel
7. Front Panel Door
8. ODD Cover
9. Front Cover Dust Filter
10. Top Panel Mesh Cover
11. Top Panel
12. Reservoir Bracket
13. Reservoir Bracket Cover
14. Bottom Radiator Bracket
15. Bottom Dust Filters
16. Tool-less ODD
17. Phanteks Logo plate
18. Front Mesh Cover
19. Hard Drive Cage
20. Hard Drive Stand
21. SSD Bracket
22. Pump Bracket
23. Side Radiator Bracket

1. Châssis
2. Panneau latéral gauche
3. Fenêtre du côté
4. Panneau latéral droit
5. Couvercle de grille du côté droit
6. Panneau frontal
7. Porte du panneau frontal
8. Couvercle du ODD
9. Filtre de poussière du couvercle frontal
10. Couvercle de grille du panneau supérieur
11. Panneau supérieur
12. Support du réservoir

13. Couvercle du support du réservoir
14. Support du radiateur inférieur
15. Filtres de poussière inférieurs
16. ODD sans outils
17. Plaque du logo Phanteks
18. Couvercle de grille du panneau frontal
19. Enclos du disque dur
20. Support du disque dur
21. Support SSD
22. Support de pompe
23. Support de radiateur latéral

1. Gehäuse
2. Linke Seitenblende
3. Seitliches Fenster
4. Rechte Seitenblende
5. Rechte Blende – Gitterabdeckung
6. Frontblende
7. Frontblendentür
8. Abdeckung für optisches Laufwerk
9. Frontabdeckung-Staubfilter
10. Deckblende – Gitterabdeckung
11. Deckblende
12. Reservoir-Halterung

13. Reservoir-Halterungsabdeckung
14. Untere Kühlkörperhalterung
15. Untere Staubfilter
16. Werkzeugloses optisches Laufwerk
17. Phanteks-Logoplatte
18. Vordere Gitterabdeckung
19. Festplattenkäfig
20. Festplattenständer
21. SSD-Halterung
22. Pumpenhalterung
23. Seitliche Kühlkörperhalterung

1. Telaio
2. Pannello laterale sinistro
3. Finestra laterale
4. Pannello laterale destro
5. Copertura di rete laterale destra
6. Pannello frontale
7. Sportello pannello frontale
8. Coperchio ODD
9. Copertura frontale filtro antipolvere
10. Copertura di rete pannello superiore
11. Pannello superiore
12. Staffa serbatoio

13. Copertura staffa serbatoio
14. Staffa inferiore radiatore
15. Filtri antipolvere inferiori
16. ODD ad incastro
17. Piastra logo Phanteks
18. Copertura di rete frontale
19. Cage disco rigido
20. Supporto disco rigido
21. Staffa SSD
22. Staffa della pompa
23. Staffa radiatore laterale

1. Chassi
2. PaineL Lateral Esquermo
3. Janela Lateral
4. PaineL Lateral Direito
5. Tampa de Malha Lateral Direita
6. PaineL frontal
7. Porta do PaineL Frontal
8. Cobertura ODD
9. Tampa Dianteira filtro de poeira
10. Tampa de Malha do PaineL Superior
11. PaineL Superior
12. Suporte do Reservatório

13. Tampa do Suporte do Reservatório
14. Suporte do Radiador Inferior
15. Filtros de Pó Inferiores
16. ODD sem Ferramenta
17. Placa de Logotipo Phanteks
18. Tampa de malha frontal
19. Berço do Disco Rígido
20. Suporte do Disco Rígido
21. Suporte do SSD
22. Suporte da Bomba
23. Suporte do Radiador Lateral





1. Chasis
2. Panel lateral izquierdo
3. Ventana lateral
4. Panel lateral derecho
5. Cubierta de malla del lateral derecho
6. Panel frontal
7. Puerta del panel frontal
8. Cubierta de la unidad de disco óptico
9. Filtro de polvo de la cubierta frontal
10. Cubierta de malla del panel superior
11. Panel superior
12. Soporte del depósito





13. Cubierta del soporte del depósito
14. Soporte del radiador inferior
15. Filtros de polvo inferiores
16. Unidad de disco óptico sin herramientas
17. Placa con logotipo de Phanteks
18. Cubierta de malla frontal
19. Compartimento de disco duro
20. Soporte de disco duro
21. Soporte de unidad de estado sólido
22. Soporte de bomba
23. Soporte del radiador lateral





1. Behuizing
2. Linker zijpaneel
3. Zij raam
4. Rechter zijpaneel
5. Rechterzijde mesh dekseL
6. Voorpaneel
7. Voorpaneel deur
8. ODD dekseL
9. VoordekseL stoffilter
10. Toppaneel mesh dekseL
11. Toppaneel
12. Reservoir beugel

13. Reservoir beugel dekseL
14. Bodem radiator rek
15. Bodem stoffilter
16. Gereedschapsloos ODD bevestiging
17. Phanteks logoplaat
18. Voorzijde mesh dekseL
19. Harde schijf kooi
20. Harde schijf stand
21. SSD beugel
22. Pomp beugel
23. Zij radiator beugel

3. ACCESSORIES



ITEM	DESCRIPTION	USE	QTY
	Screw M3 x 5mm	Motherboard/ ODD/SSD	28
	Stand Off Screws	Motherboard	5
	Screw 6-32 x 6mm	PSU	9
	Thumb Screws 6-32 x 6mm	PSU, Brackets, HDD cages	10
	Screw 6-32 x 31mm	Front/HDD fans	10

ITEM	DESCRIPTION	USE	QTY
	Screw 5 x 10KT	Fan installation	12
	Screw M4 x 8mm	Reservoir Bracket	8
	CM6 #11	HDD	12
	CM6 #5	Pump Bracket	5
	PWM6# x 6mm	Hook n Loop Screw	2

ITEM	DESCRIPTION	USE	QTY
	150mm	Zip Tie	10
	188 x 10 x 1.8mm	Hook n Loop (long)	1
	110 x 10 x 1.8mm	Hook n Loop (short)	1
	Rubber Stand	2nd PSU	2

ITEM	DESCRIPTION	USE	QTY
	Aluminum Plate	Logo Plate	1

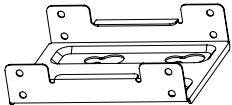
4. BRACKETS

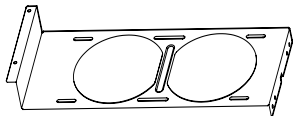
	SSD Bracket Support SSD SSD-Halterung Staffa SSD Suporte do SSD Soporte de unidad de estado sólido SSD beugel
	Reservoir Bracket Support du réservoir Reservoir-Halterung Staffa serbatoio Suporte do Reservatório Soporte del depósito Reservoir beugel
	Side Radiator Bracket Support de radiateur latéral Seitliche Kühlkörperhalterung Staffa radiatore laterale Suporte do Radiador Lateral Soporte del radiador lateral Zij radiator beugel

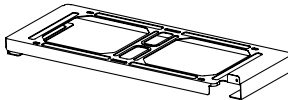
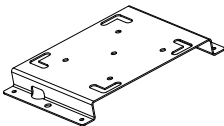
	Bottom Radiator Bracket Support du radiateur inférieur Untere Kühlkörperhalterung Staffa inferiore radiatore Suporte do Radiador Inferior Soporte del radiador inferior Bodem radiator beugel
	Pump Bracket Support de pompe Pumpenhalterung Staffa della pompa Suporte da Bomba Soporte de bomba Pomp beugel

5. I/O PORTS AND FRONT PANEL

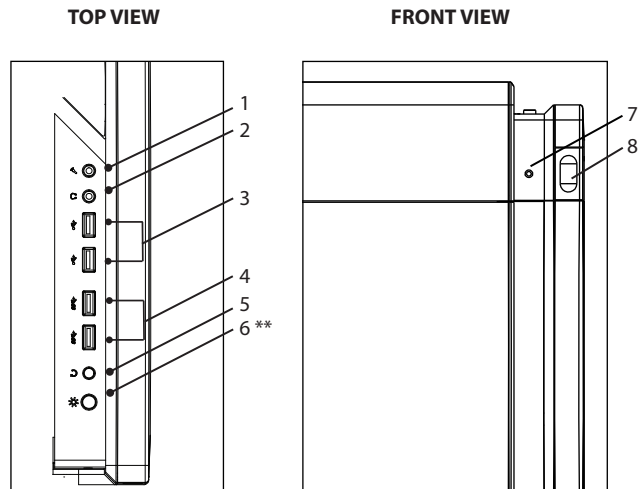

**** See page 10 for connection details.**

**** Voir page 10 pour les détails de connexion**

**** Einzelheiten zum Anschließen finden Sie auf Seite 10.**

**** Fare riferimento a pagina 10 per dettagli sul collegamento.**

**** Ver pagina 10 para detalhes de conexão.**

**** Consulte la página 10 para obtener información sobre la conexión.**

**** Zie pagina 10 voor aansluiting details**

1. Microphone
2. Headphone
3. USB 2.0
4. USB 3.0
5. Power Reset
6. LED ON/OFF Switch
7. HDD LED
8. Power Button

1. Mikrofon
2. Kopfhörer
3. USB 2.0
4. USB 3.0
5. Reset
6. LED-Ein-/Ausschalter
7. Festplatten-LED
8. Ein-/Austaste

1. Microphone
2. Casque
3. USB 2.0
4. USB 3.0
5. Réinitialisation de l'alimentation
6. Bouton MARCHÉ/ARRÊT LED
7. HDD LED
8. Bouton d'alimentation

1. Microfone
2. Fone de ouvido
3. USB 2.0
4. USB 3.0
5. Redefinição de Energia
6. Interruptor LIGA/DESLIGA do LED
7. HDD LED
8. Botão de Alimentação

1. Microfono
2. Cuffie
3. USB 2.0
4. USB 3.0
5. Ripristino alimentazione
6. LED interruttore d'accensione/ spegnimento
7. LED HDD
8. Tasto d'alimentazione

1. Micrófono
2. Cascos
3. USB 2.0
4. USB 3.0
5. Resetear
6. Interruptor LED de encendido/ apagado
7. LED de la unidad de disco duro
8. Botón de alimentación

1. Microfoon
2. Hoofdtelefoon
3. USB 2.0
4. USB 3.0
5. Power Reset
6. LED aan/uit knop
7. HDD LED
8. Power knop

6. CONNECTIONS

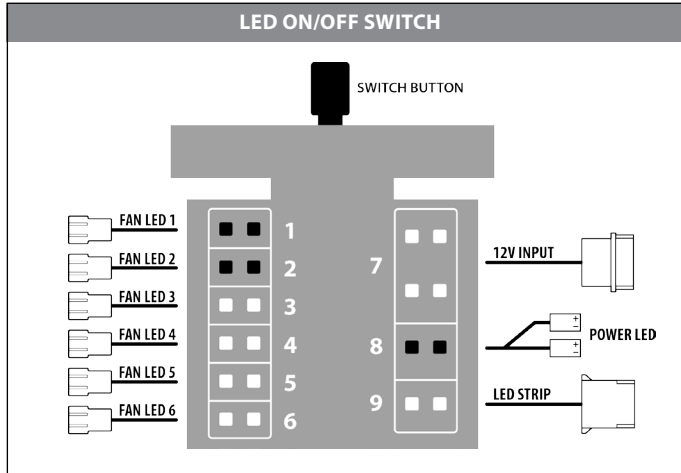

*Slot 1, 2, and 8 are occupied.

Per Fan LED Line (1-6)	>100mA
Power LED connections (8)	<1A
Optional LED Strip Connection (9) (max 50 LEDs per connection)	<1A

* 4 unoccupied connectors for Phanteks LED fans upgrades (3-6)

** Molex output connector for LED Strips (9).

* 4 connecteurs non utilisés pour mettre à jour les ventilateurs LED de Phanteks (3-6)

** Connecteur de sortie Molex pour les bandes LED (9).

* 4 freie Anschlüsse zur Phanteks-LED-Lüfteraufrüstung (3-6)

** Molex-Ausgang für LED-Leisten (9).

* 4 connettori non occupati per l'aggiornamento delle ventole a LED Phanteks (3-6)

** Connettore uscita Molex per strisce LED (9).

* 4 conectores desocupados para atualizações de ventoinhas LED Phanteks (3-6)

** Conector de saída Molex para Tiras de LED (9).

* 4 conectores disponibles para actualizaciones de ventiladores LED de Phanteks (3-6)

** Conector de salida Molex para tiras de LED (9).

* 4 lege aansluitingen voor Phanteks LED ventilatoren (3-6)

** Molex uitgang connector voor LED strips (9).

6. CONNECTIONS

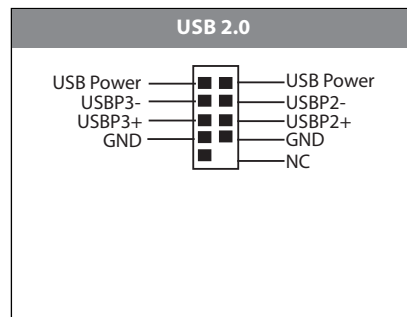
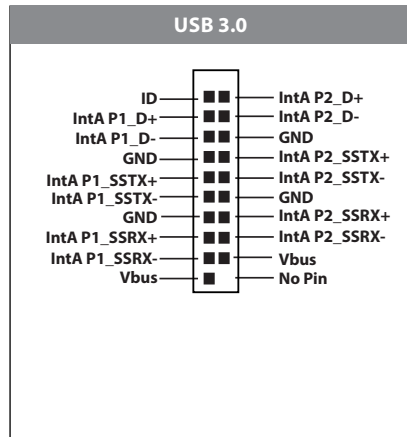
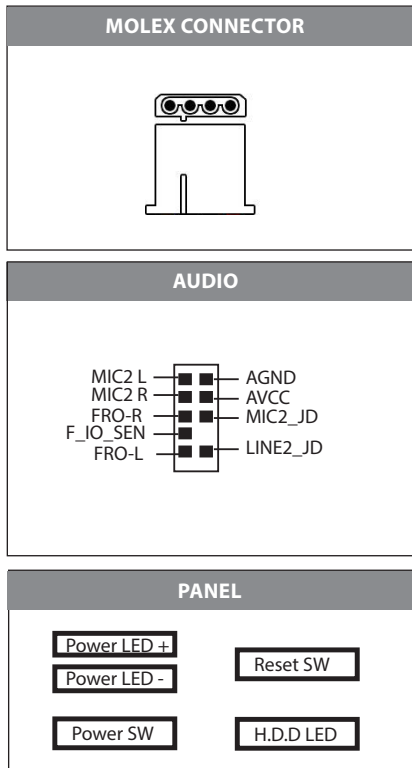

7. PANEL REMOVAL

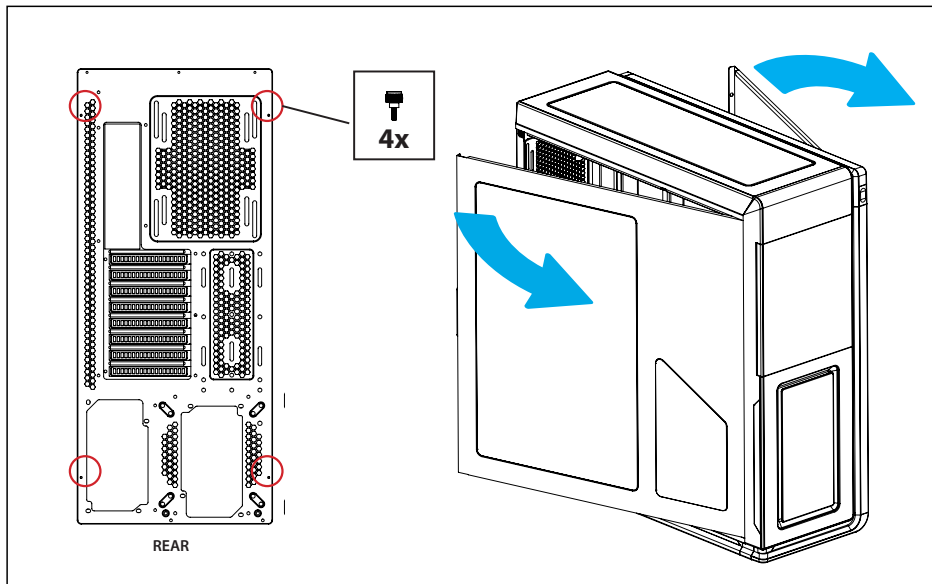

Unscrew the 4 thumb screws to remove the side panels.

Dévissez les vis à main pour enlever les panneaux latéraux.

Lösen Sie die 4 Rändelschrauben zum Entfernen der seitlichen Blenden.

Svitare le 4 viti per rimuovere i pannelli laterali.

Desaperte os 4 parafusos para remover os painéis laterais.

Desatornille los 4 tornillos de pulgar para retirar los paneles laterales.

Schroef 4 duimschroeven los om de zijpanelen te verwijderen.

7. PANEL REMOVAL

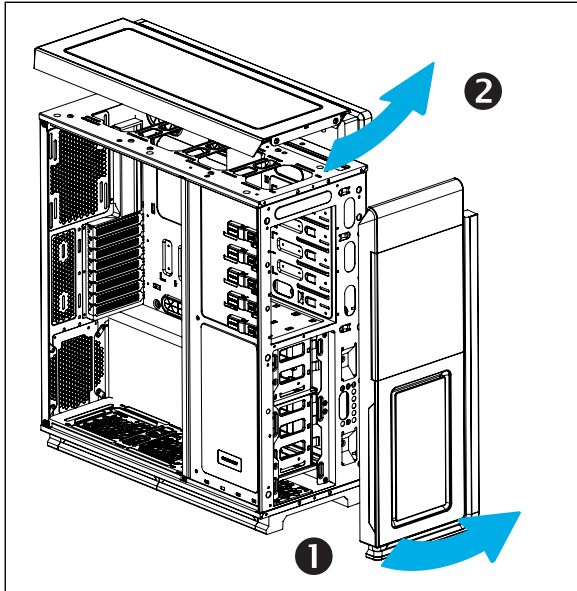

**** To prevent damage to the panels, please follow the steps in order.**

Step 1: Pull outward to remove the front panel.

Step 2: Pull up to remove the top panel.

**** Pour éviter d'endommager les panneaux, veuillez suivre les étapes suivantes dans l'ordre.**

Etape 1 : Tirez pour enlever le panneau frontal.

Etape 2 : Tirez vers le haut pour enlever le panneau supérieur.

**** Bitte folgen Sie zur Vermeidung von Schäden an den Blenden die Schritte der Reihe nach.**

Schritt 1: Frontblende zum Entfernen nach außen ziehen.

Schritt 2: Deckblende zum Entfernen nach oben ziehen.

**** Per evitare di danneggiare i pannelli, attenersi con ordine alle fasi.**

Fase 1: tirare verso l'esterno per rimuovere il pannello frontale.

Fase 2: sollevare per rimuovere il pannello superiore.

**** Para evitar danos aos painéis, por favor siga as instruções abaixo em ordem.**

Etapa 1: Puxe para fora para remover o painel frontal.

Etapa 2: Puxe para cima para remover o painel superior.

**** Para evitar dañar los paneles, siga los siguientes pasos en orden:**

Paso 1: tire del panel frontal hacia afuera para quitarlo.

Paso 2: tire del panel superior hacia arriba para retirarlo.

**** Om schade aan de panelen te voorkomen, volg dan de stappen in deze volgorde:**

Stap 1: trek naar buiten om de voorpaneel te verwijderen

Stap 2: trek naar boven om de toppaneel te verwijderen

**** Use caution when removing front panel, Power LED wires are attached to front panel.**

**** Faites attention lorsque vous retirez le panneau frontal, les fils LED d'alimentation sont attachés au panneau frontal.**

**** Gehen Sie beim Entfernen der Frontblende vorsichtig vor, die Drähte der Betriebsanzeige-LED sind an der Frontblende befestigt.**

**** Usare cautela nella rimozione del pannello frontale, i cavi del LED d'alimentazione sono collegati al pannello frontale.**

**** Cuidado quando remover o painel frontal, os cabos do LED de energia são conectados ao painel frontal.**

**** Tenga cuidado cuando quite el panel frontal, ya que los cables LED de alimentación están sujetos al panel frontal.**

**** Wees voorzichtig bij het verwijderen van de voorpaneel, Power LED bedradingen zijn aan de voorpaneel bevestigd.**

8. MOTHERBOARD INSTALLATION

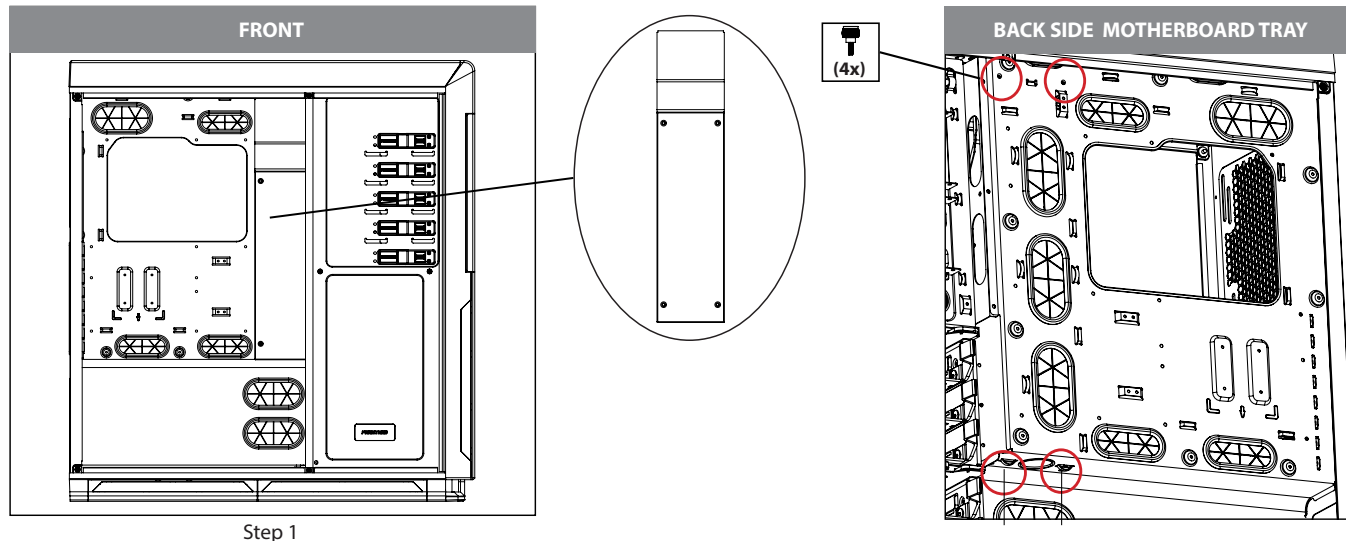

Step 1

Step 1: Remove the reservoir bracket by unscrewing the four screws before you install the motherboard.

Etape 1 : Retirez le support de réservoir en dévissant les quatre vis avant d'installer la carte mère.

Schritt 1: Entfernen Sie die Reservoir-Halterung, indem Sie die vier Schrauben lösen, bevor Sie das Motherboard installieren.

Fase 1: rimuovere la staffa del serbatoio svitando le quattro viti prima di installare la scheda madre

Etapa 1: Extrair o suporte do reservatório, soltando os quatro parafusos antes de instalar a placa mãe.

Paso 1: tire del soporte del depósito desatornillando los cuatro tornillos antes de instalar la placa base.

Stap 1: Verwijder het reservoir beugel door de vier schroeven los te draaien voordat u het moederbord installeert.

8. MOTHERBOARD INSTALLATION

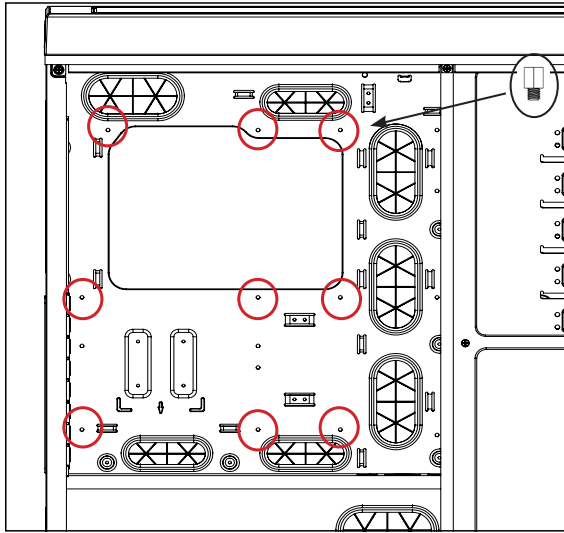

Step 2

Step 2: Standoff screws are pre-installed for ATX. Extra standoff required for E-ATX

Etape 2 : Des vis standoff sont pré-installés pour ATX. D'autres vis standoff sont nécessaire pour E-ATX

Schritt 2: Abstandhalterschrauben sind bei ATX vorinstalliert. Bei E-ATX sind zusätzliche Abstandhalter erforderlich

Fase 2: i pilastri a vite sono pre-installati per ATX. E-ATX necessita di pilastri a vite extra

Etapa 2: Os parafusos espaçadores são pré-instalado ao ATX. Espaçadores extra requeridos para E-ATX

Paso 2: se incluyen tornillos separadores preinstalados para ATX. Para E-ATX se necesitan más separadores

Stap 2: afstandschroeven zijn vooraf geïnstalleerd voor ATX. Extra afstandschroeven zijn vereist voor E-ATX

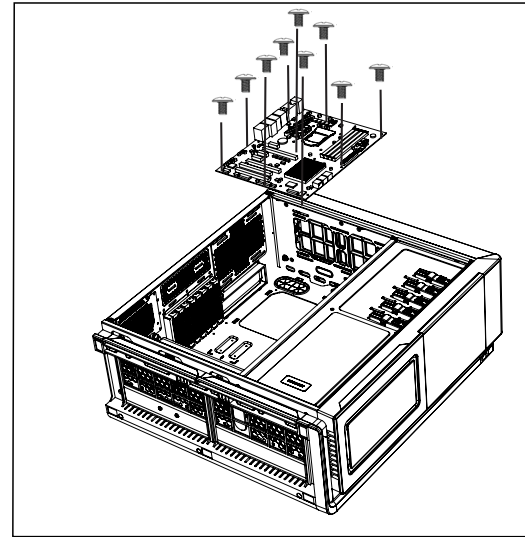

Step 3

Step 3: Install the motherboard with the provided M3 screws.

Etape 3 : Installez la carte mère avec les vis M3 fournies.

Schritt 3: Installieren Sie das Motherboard mit den mitgelieferten M3-Schrauben.

Fase 3: installare la scheda madre con le viti M3 fornite in dotazione.

Etapa 3: Instale a placa mãe com os parafusos M3 fornecidos.

Paso 3: instale la placa base con los tornillos M3 que se suministran.

Stap 3 : Installeer het moederbord met de meegeleverde M3- schroeven

9. POWER SUPPLY INSTALLATION

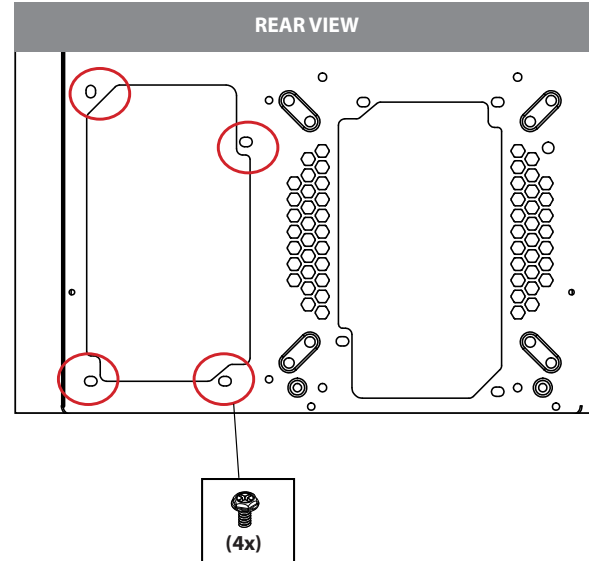
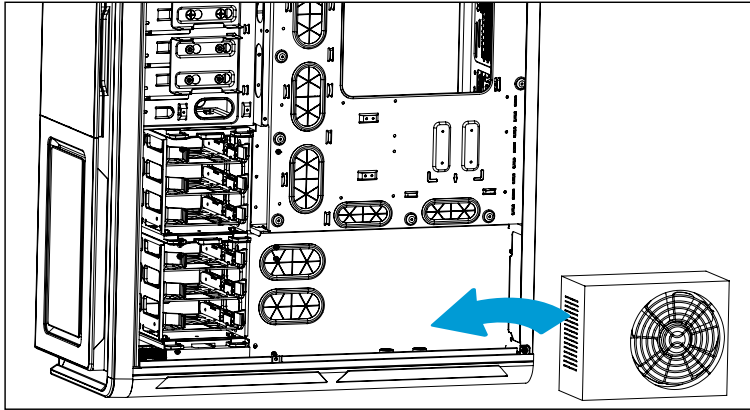

Use the provided screws to secure the PSU in place.

Utilisez les vis fournies pour fixer le bloc d'alimentation en place.

Befestigen Sie das Netzteil mit den mitgelieferten Schrauben.

Utilizzare le viti fornite per fissare la PSU in sito.

Use os parafusos para fixar a Unidade de Proteção e de Comutação.

Utilice los tornillos suministrados para fijar la fuente de alimentación en su posición.

Gebruik de meegeleverde schroeven om de voeding vast te zetten.

9. PSU INSTALLATION (OPTIONAL)

* Unscrew the panel to reveal the psu mounting location

* Dévissez le panneau pour pouvoir accéder à l'emplacement de montage de la PSU.

* Lösen Sie die Blende zum Zugreifen auf die Netzteilmontageposition.

* Svitare il pannello per rivelare la posizione d'installazione della PSU.

* Desaparafuse o painel para revelar o local de montagem do PSU.

* Desatornille el panel para ubicar el lugar de montaje de la fuente de alimentación

* Schroef het paneel los om de voeding installatie locatie te onthullen.

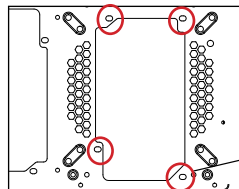
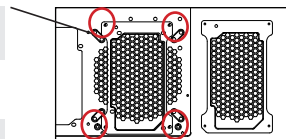

Rear

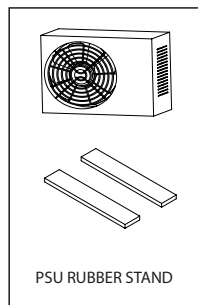

** We recommend this install as your optional PSU location. Airflow will be restricted if PSU is installed.

** Nous recommandons ce type d'installation car l'emplacement optionnel pour la PSU sera limité si la PSU est installé.

** Wir empfehlen diese Installation als optionale Netzteilposition. Die Luftzirkulation wird beeinträchtigt, falls hier ein Netzteil installiert wird.

** Si consiglia questa installazione perché il flusso d'aria della posizione PSU optional sarà limitato se è installata la PSU.

** Recomendamos esta instalação pois o seu local fluxo de ar PSU opcional será limitado se PSU for instalado.

** Le recomendamos que lo instale como su lugar de la fuente de alimentación opcional. El flujo de aire se restringirá si instala la fuente de alimentación.

** Wij raden deze locatie aan voor uw optionele voeding. Luchstroom zal worden beperkt indien een voeding hier wordt geïnstalleerd.

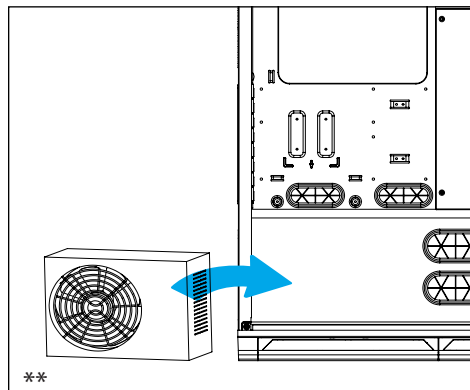

Align the PSU with the mounting holes and use the screws to secure the PSU to the chassis.

Aligner la PSU avec les trous de montage et utilisez les vis pour fixer le PSU au châssis.

Richten Sie das Netzteil an den Montagelöchern aus, befestigen Sie das Netzteil mit Schrauben am Gehäuse.

Allineare la psu con i fori d'installazione ed utilizzare le viti per fissare la psu al telaio.

Alinhe o PSU com os orifícios de montagem e use os parafusos para fixar a Unidade de Proteção e de comutação ao chassi.

Alinee la fuente de alimentación con los agujeros de montaje y utilice los tornillos para fijar la fuente de alimentación al chasis.

Lijn de voeding uit met de montagegaten en gebruik de schroeven om de voeding vast te zetten aan de behuizing.

10. FILTERS REMOVAL

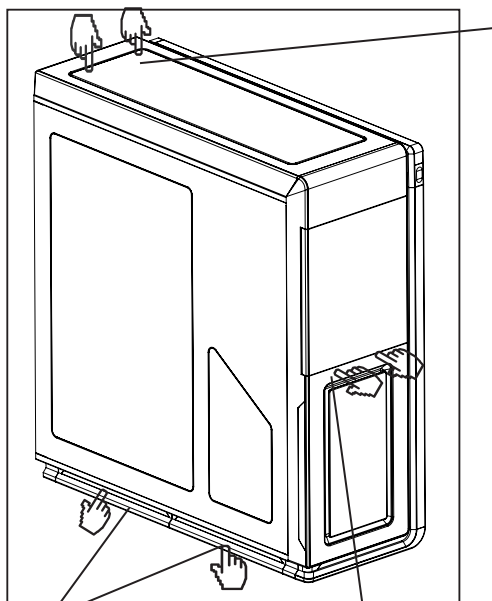

Push down

Poussez vers le bas
 Nach unten drücken
 Spingere verso il basso
 Empurre para baixo
 Apriete hacia abajo
 Druk in

Push in to remove

Poussez pour enlever
 Zum Entfernen nach innen drücken
 Spingere verso l'interno per rimuovere
 Pressione para remover
 Pulse para retirarlo
 Druk in om te verwijderen

Push in to remove

Poussez pour enlever
 Zum Entfernen nach innen drücken
 Spingere verso l'interno per rimuovere
 Pressione para remover
 Pulse para retirarlo
 Druk in om te verwijderen

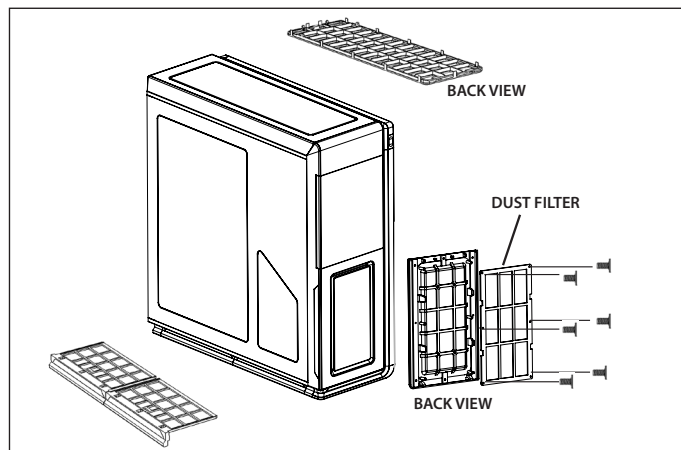

To clean the dust filters, run slow moving water through the filters. Dry filters before reinstalling.

Pour nettoyer les filtres à poussière, faites couler de l'eau sur les filtres.
 Séchez les filtres avant de réinstaller.

Reinigen Sie die Staubfilter, indem Sie sie unter langsam fließendem Wasser abspülen.
 Filter vor Wiedereinbau trocknen.

Per pulire i filtri antipolvere, far correre lentamente l'acqua attraverso i filtri.
 Asciugare i filtri prima di installarli di nuovo.

Para limpar os filtros de poeiras, passe água em movimento lento através dos filtros.
 Seque os filtros antes de reinstalar.

Para limpiar los filtros de polvo, deje que caiga agua corriente lentamente sobre los filtros.
 Seque los filtros antes de volverlos a colocar.

Laat langzaam stromend water door de filter lopen voor het reinigen van de filters. Droog de filters voordat u het weer bevestigd.

11. FAN COMPATIBILITY

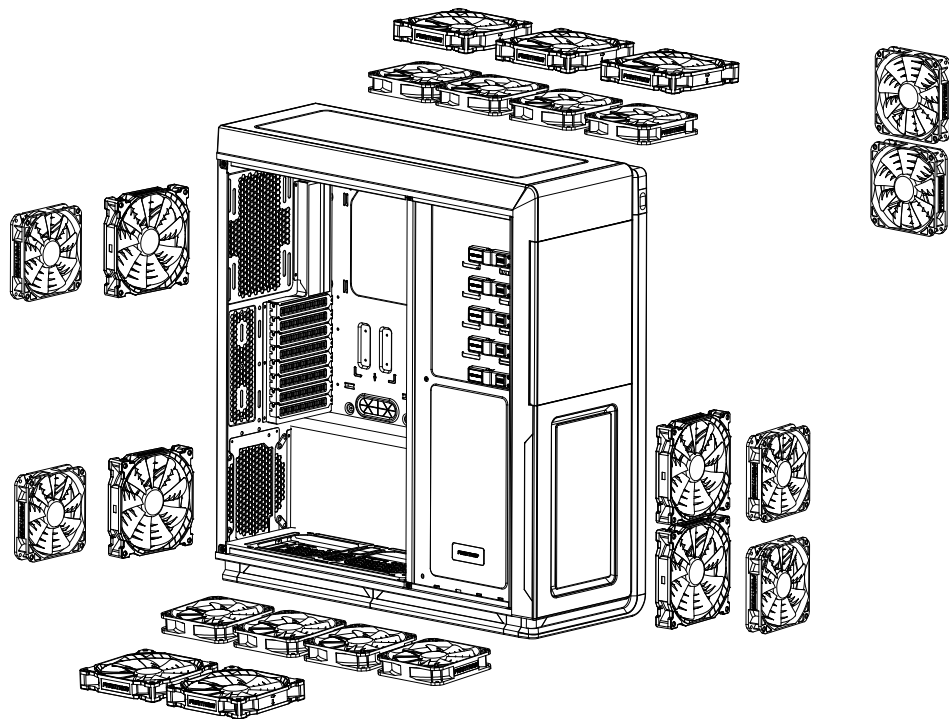

FAN COMPATIBILITY TABLE

	140mm	120mm
Top	3 (1x included)	4
Bottom	2 (1x included)	4
Front	2 (2x LED fan included)	2
Rear (Top)	1 (1x included)	1
Rear (Bottom)	1	1
Side	2	2
HDD Cages		2

12. PWM HUB

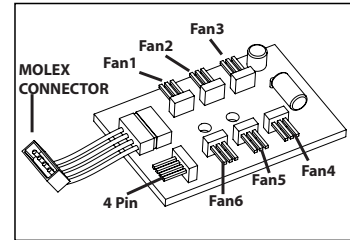
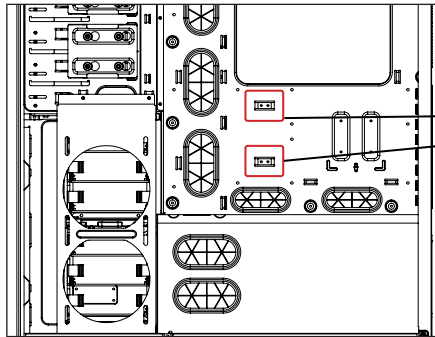

PWM Hub can be mounted on different locations.

Le hub PWM peut être monté sur des endroits différents.

PWM-Hub kann an verschiedenen Positionen montiert werden.

L'hub PWM può essere montato su posizioni diverse.

O PWM Hub pode ser montado em diferentes locais.

El conector de modulación por ancho de pulso se puede montar en diferentes lugares.

PWM Hub kan op verschillende locaties worden gemonteerd.

PWM hub will enable PWM function to 3-pin fans. Fan 1 can only be connected to one fan and cannot be split. Fan 2 - Fan 6 can be split to multiple fans. Total of 11 fans can be connected to the PWM hub. All PWM functions will be controlled by fan 1.

Le hub PWM permettra le fonctionnement PWM pour les ventilateurs à 3 broches. Ventilateur 1 ne peut être relié qu'à un ventilateur et ne peut être divisé. Ventilateur 2 - 6 peuvent être divisés entre plusieurs ventilateurs. Un nombre total de 11 ventilateurs peuvent être reliés au hub PWM. Toutes les fonctions PWM seront contrôlés par le ventilateur 1.

Der PWM-Hub stattet 3-polige Lüfter mit der PWM-Funktion aus. Lüfter 1 kann nur mit einem Lüfter verbunden und nicht aufgeteilt werden. Lüfter 2 bis Lüfter 6 können auf mehrere Lüfter aufgeteilt werden. Insgesamt können 11 Lüfter mit dem PWM-Hub verbunden werden. Die gesamte PWM-Funktion wird über Lüfter 1 gesteuert.

L'hub pwm abiliterà la funzione pwm per le ventole a 3 pin. fan 1 può essere collegato solo ad una ventola e non può essere diviso. fan 2 - fan 6 possono essere divisi tra più ventole. all'hub pwm può essere collegato ad un totale di 11 ventole. tutte le funzioni pwm saranno controllate da fan 1.

PWM Hub irá permitir função PWM de ventoinhas de 3 pinos. Ventoinha 1 pode apenas ser conectada a uma ventoinha e não pode ser dividida. Ventoinha 2 - Ventoinha 6 podem ser divididas para várias ventoinhas. Total de 11 ventoinhas podem ser conectadas ao PWM Hub. Todas as funções PWM serão controladas pela ventoinha 1.

El conector de modulación por ancho de pulso habilitará la función de modulación por ancho de pulso en ventiladores de 3 pines. El ventilador 1 sólo puede conectarse a un ventilador y no se puede dividir. Los ventiladores del 2 al 6 pueden dividirse en varios ventiladores. Se pueden conectar un total de 11 ventiladores al conector de modulación por ancho de pulso. El ventilador 1 controlará todas las funciones de modulación por ancho de pulso.

PWM hub maakt 3-pin ventilatoren geschikt voor PWM-functie. Ventilator 1 kan alleen worden aangesloten op 1 ventilator en kan niet worden gesplitst. Ventilator 2 - Ventilator 6 kunnen worden gesplitst naar meerdere ventilatoren. In totaal kunnen 11 ventilatoren worden aangesloten op de PWM hub. Alle PWM-functies zullen worden bestuurd door ventilator 1.

13. SSD/ODD INSTALLATION

SSD INSTALLATION

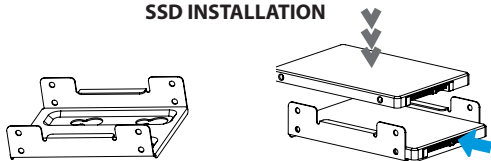

Slide in the bottom SSD and place the second on top then screw in to lock.

Faites glisser le SSD en bas et placez le deuxième au-dessus puis serrez les vis pour verrouiller

Schieben Sie die untere SSD hinein und bringen die zweite darauf an, dann festschrauben

Far scorrere l'unità SSD inferiore e collocarci sopra il secondo, quindi avvitare per bloccare

Deslize o SSD inferior e coloque a segunda na parte no topo, em seguida, aperte a trava Deslice la unidad de estado sólido inferior y coloque la segunda en la parte superior, a continuación atornillela para fijarla.

Deslice la unidad de estado sólido inferior y coloque la segunda en la parte superior, a continuación atornillela para fijarla.

Schuif de onderste SSD in en plaats de tweede op de bovenlaag. Gebruik schroeven voor vergrendeling

DROP N LOCK

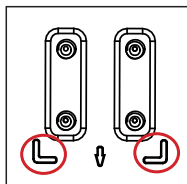

Align corner of bracket to the guide and drop down to lock.

Alignez le coin du support avec le guide et baissez-le pour verrouiller.

Richten Sie die Ecke der Halterung an der Führung aus und lassen sie einrasten.

Allineare l'angolo della staffa alla guida e calarla per bloccare.

Alinhe o canto do suporte ao guia e empurre para baixo para travar.

Alinee la esquina del soporte con la guía y empuje hacia abajo para que quede sujeta.

Plaats de beugel langs de uitlijning en druk richting de pijl om te bevestigen.

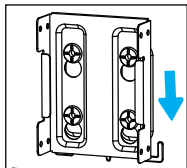

ODD INSTALLATION

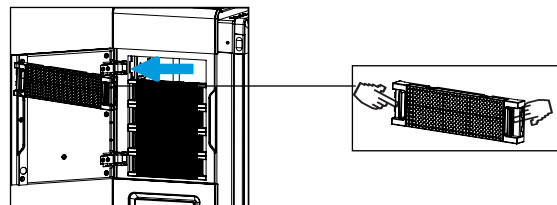

Push in the two sides to release the ODD cover.

Poussez les deux côtés pour libérer le couvercle ODD.

Drücken Sie die beiden Seiten zum Lösen der Abdeckung des optischen Laufwerks nach innen.

Spingere verso l'interno i due lati per sbloccare il coperchio ODD.

Pressione os dois lados para soltar a tampa ODD.

Pulse sobre los dos laterales para retirar la cubierta de la unidad de disco óptico.

Duw de twee kanten in om de ODD deksel los te maken

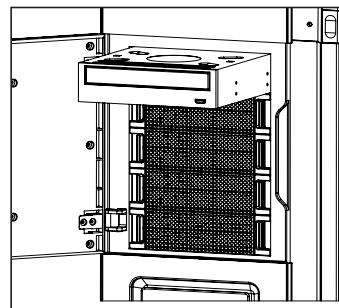

Align and slide in.

Alignez et faites glisser.

Ausrichten und hineinschieben.

Allineare e far scorrere verso l'interno.

Alinhe e deslize para dentro.

Alinheela y deslicela.

Uitlijnen en inschuiven

14. HARD DRIVE INSTALLATION

3.5" INSTALLATION

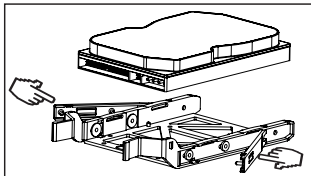
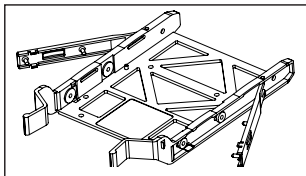

Place hard drive into tray and push in the arms to lock.

Placez le disque dur dans le logement et poussez les bras pour le verrouiller.

Bringen Sie die Festplatten im Fach an und drücken die Arme zum Verriegeln hinein.

Collocare disco rigido nel cassetto e spingere i bracci verso l'interno per bloccare.

Coloque o disco rígido na bandeja e empurre os braços para travar.

Coloque el disco duro en la bandeja y pulse sobre los brazos para que quede sujeto.

Plaats de harde schijf in de lade en duw de armen in voor vergrendeling.

2.5" INSTALLATION

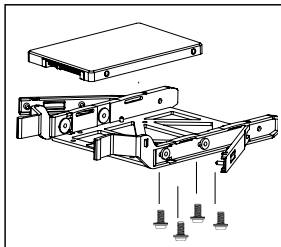

Align the SSD onto the mounting holes and screw in.

Aligner le SSD avec les trous de montage et vissez.

Richten Sie die SSD an den Montagelöchern aus und befestigen die Schrauben.

Allineare l'unità ssd su i fori di installazione e fissare le viti.

Alinhe o SSD nos orifícios de fixação e parafuse.

Alinee la unidad de estado sólido con los agujeros de montaje y atornillela.

Lijn de SSD uit op de bevestigingsgaten en schroef de schroeven in.

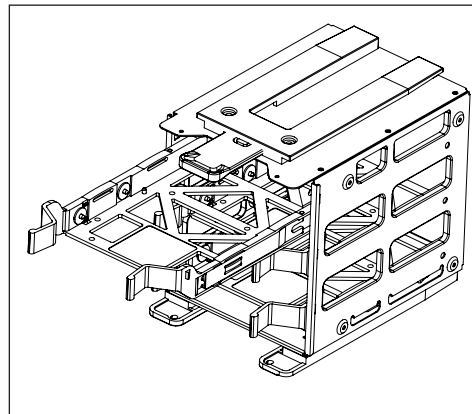

Align the tray to the HDD cage and slide in.

Alignez le plateau de l'enclos de DD et faites glisser.

Richten Sie das Fach am Festplattenkäfig aus und schieben es hinein.

Allineare il cassetto alla gabbia HDD e farlo scorrere verso l'interno.

Alinhe a bandeja no berço do HDD e deslize.

Alinee la bandeja con el compartimento de la unidad del disco duro y deslícela.

Leg de slede in positie in de HDD kooi en schuif deze in

14. HARD DRIVE INSTALLATION

REMOVING HDD CAGES

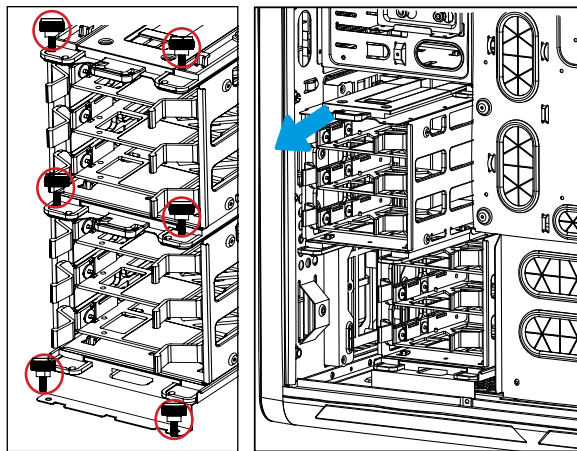

Unscrew the thumbscrews to remove the cages.

Dévissez les vis à main pour enlever les cages.

Lösen Sie die Rändelschrauben zum Entfernen der Käfige.

Svitare le viti per rimuovere le cage.

Desaperte os parafusos para remover os berços.

Desatornille los tornillos de pulgar para retirar los compartimentos.

Schroef de duimschroeven los om de kooien te verwijderen

REPOSITIONING OF HDD CAGES

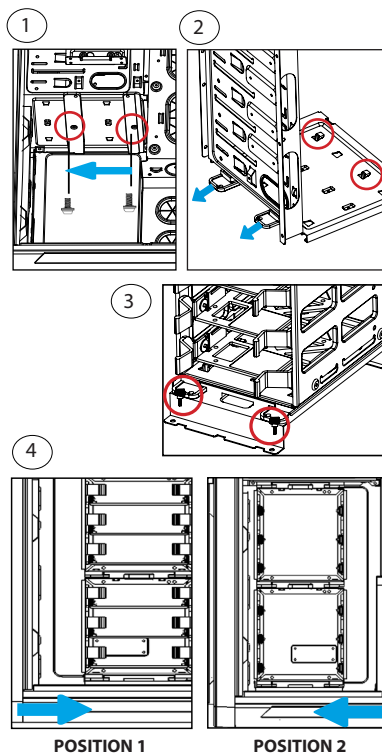

1. Unscrew the rails under ODD
2. Pull tab out to release
3. Remove thumbscrew on the HDD cage stand
4. Reposition to alternate placement

1. Dévissez les rails sous ODD.
2. Tirez l'onglet pour le libérer.
3. Retirez les vis à main du support de cage de HDD.
4. Replacer selon l'orientation choisie

1. Schienen unter ODD lösen
2. Lasche zum Lösen herausziehen
3. Rändelschraube am Festplattenkäfigständer entfernen
4. Zum Ändern des Ortes neu positionieren

1. Svitare le guide sotto l'ODD
2. Tirare la linguetta verso l'esterno per sbloccare
3. Rimuovere le viti dal supporto cage HDD
4. Ricollocare sulla posizionamento alternativa

1. Desparafuse os trilhos sob ODD
2. Puxe a aba para fora para soltar
3. Remova o parafuso do suporte do berço do HDD
4. Repositione para colocação alternada

1. Desatornille las guías de debajo del ODD
2. Tire de las lengüetas para quitarlo
3. Retire el tornillo de pulgar del soporte del compartimento de la unidad del disco duro
4. Vuelva a colocarlo en otro lugar

1. Schroef de rails los onder ODD
2. Trek hendel uit om vrij te geven
3. Verwijder de duimschroeven van de HDD kooi stand
4. Herpositioneer voor alternatieve plaatsing

15. WATERCOOLING INSTALLATION

WATERCOOLING RADIATOR COMPATIBILITY

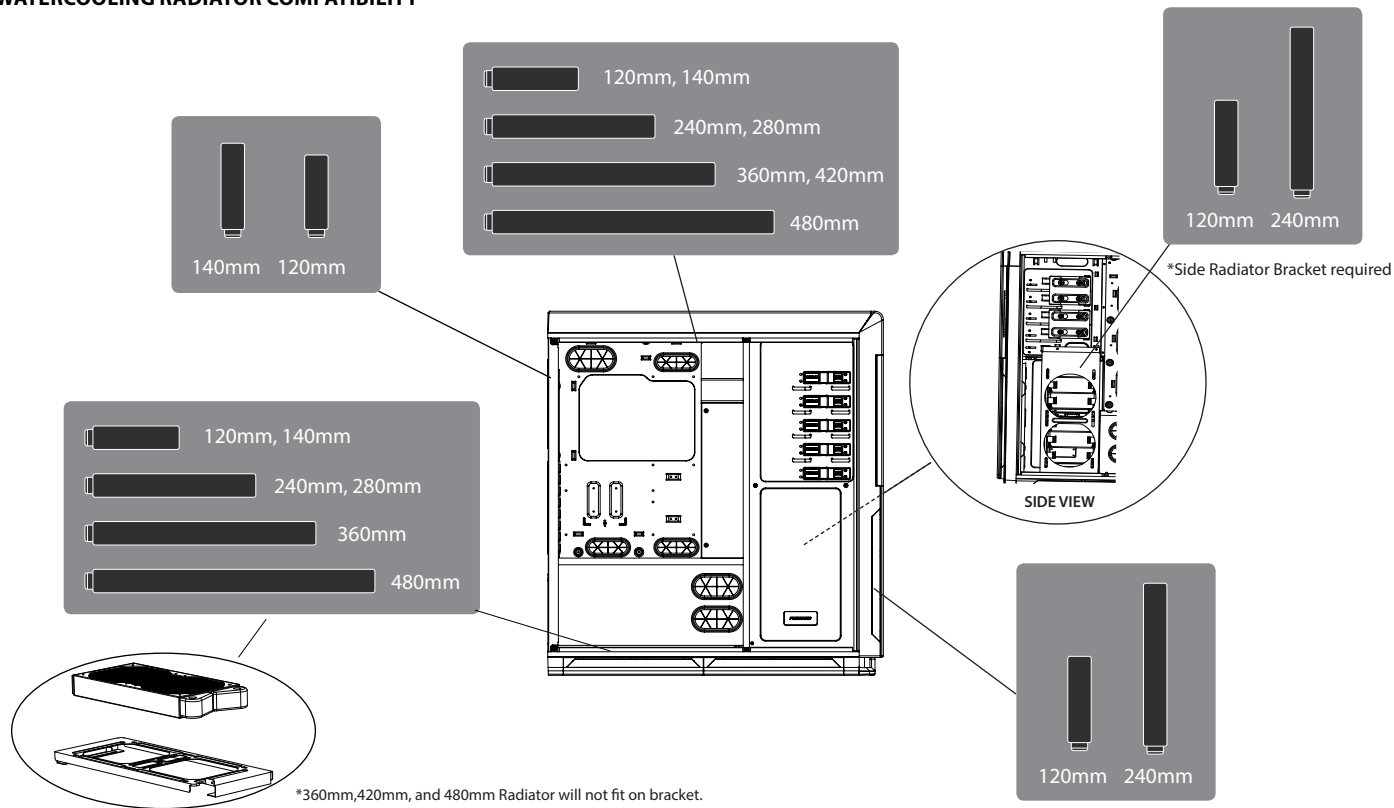

15. WATERCOOLING INSTALLATION

120 MM FORM FACTOR RADIATORS

Radiator Size	Front	Rear	Bottom	Top	Side(w/o HDD Cages)
Taille de radiateur Kühlkörpergröße Dimensioni del radiatore Tamanho do radiador Tamaño del radiador Radiador lengte	Avant Vorderseite Parte frontale Frente Frontal Voorkant	Arrière Rückseite Parte posteriore Traseira Posterior Achterkant	Dessous Unterseite Parte inferiore Base Inferior Bodem	Dessus Oberseite Parte superiore Topo Superior Bovenkant	Côté (sans les cages de DD) Seite (ohne Festplattenkäfig) Parte laterale (senza cage HDD) Lado (sem berços de HDD) Lateral (sin compartimentos de unidades de disco duro) Zijkant (zonder de HDD kooien)
120mm	✓	✓	✓	✓	✓
240mm	✓		✓	✓	✓
360mm			✓ ***	✓	
480mm			✓ ***	✓ **(70mm thickness max)	

***Caution: Supported Radiator size and thickness varies depending on your setup.**

*Avertissement : Les tailles de radiateur et les épaisseurs supportées varient en fonction de votre configuration.

*Achtung: Unterstützte Kühlkörpergröße und -dicke variieren je nach Aufbau.

*Attenzione: Le dimensioni e lo spessore supportati per il radiatore dipendono dalla configurazione.

*Atenção: O tamanho e espessura do Suporte do Radiador variam dependendo da configuração.

*Precaución: el grosor y el tamaño del radiador compatibles varían según la instalación que realice.

*Let op : Ondersteunde radiator grootte en dikte varieert afhankelijk van de opstelling.

**** 70mm thickness max**

** Épaisseur max de 70mm

** Max. 70 mm dick

** Spessore 70 mm al massimo

** 70Mm de espessura máx.

** 70mm de grosor como máximo

** 70mm dikte max.

***** 125mm width max**

*** largeur max de 125mm

*** Max. 125 mm

*** larghezza 125 mm al massimo

*** 125Mm de larguar máx.

*** 125mm de ancho como máximo

*** 125mm breedte max.

15. WATERCOOLING INSTALLATION

140 MM FORM FACTOR RADIATORS

Radiator Size	Front	Rear	Bottom	Top	Side(w/o HDD Cages)
Taille de radiateur Kühlkörpergröße Dimensioni del radiatore Tamanho do radiador Tamaño del radiador Radiador lengte	Avant Vorderseite Parte frontale Frente Frontal Voorkant	Arrière Rückseite Parte posteriore Traseira Posterior Achterkant	Dessous Unterseite Parte inferiore Base Inferior Bodem	Dessus Oberseite Parte superiore Topo Superior Bovenkant	Côté (sans les cages de DD) Seite (ohne Festplattenkäfig) Parte laterale (senza cage HDD) Lado (sem berços de HDD) Lateral (sin compartimentos de unidades de disco duro) Zijkant (zonder de HDD kooien)
140mm		✓	✓***	✓	
280mm			✓***	✓	
420mm				✓ **(70mm thickness max)	

***Caution: Supported Radiator size and thickness varies depending on your setup.**

*Avertissement : Les tailles de radiateur et les épaisseurs supportées varient en fonction de votre configuration.

*Achtung: Unterstützte Kühlkörpergröße und -dicke variieren je nach Aufbau.

*Attenzione: Le dimensioni e lo spessore supportati per il radiatore dipendono dalla configurazione.

*Atenção: O tamanho e espessura do Suporte do Radiador variam dependendo da configuração.

*Precaución: el grosor y el tamaño del radiador compatibles varían según la instalación que realice.

*Let op : Ondersteunde radiator grootte en dikte varieert afhankelijk van de opstelling.

**** 70mm thickness max**

** Épaisseur max de 70mm

** Max. 70 mm dick

** Spessore 70 mm al massimo

** 70Mm de espessura máx.

** 70mm de grosor como máximo

** 70mm dikte max.

***** 125mm width max**

*** largeur max de 125mm

*** Max. 125 mm

*** larghezza 125 mm al massimo

*** 125Mm de larguar máx.

*** 125mm de ancho como máximo

*** 125mm breedte max.

15. WATERCOOLING INSTALLATION

RADIATOR BRACKETS

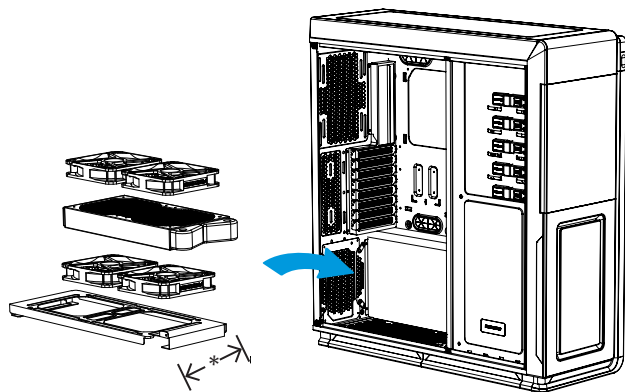
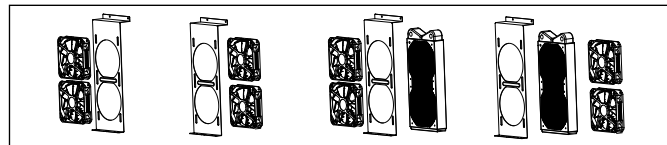
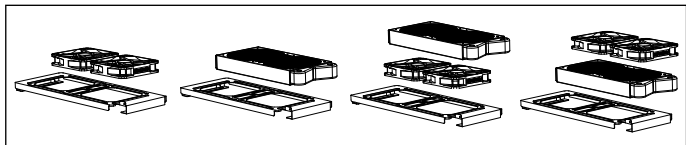

*Bottom Radiator Bracket

*Support du radiateur inférieur

*Untere Kühlkörperhalterung

*Staffa inferiore radiatore

*Suporte do Radiador Inferior

*Soporte del radiador inferior

*Bodem radiator beugel

* 145 mm max

* max de 145mm

* Max. 145 mm

* 145 mm al massimo

* 145Mm máx.

* 145mm de máximo

* 145mm max.

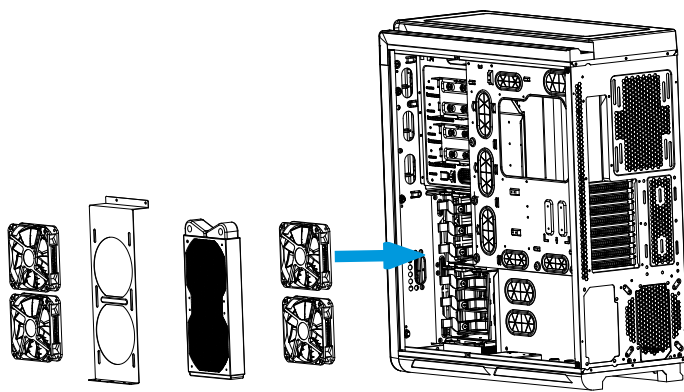

*Side Radiator Bracket

Support de radiateur latéral

Seitliche Kühlkörperhalterung

Staffa radiatore laterale

Suporte do Radiador Lateral

Soporte del radiador lateral

Zij radiator beugel

15. WATERCOOLING INSTALLATION

PUMP BRACKET

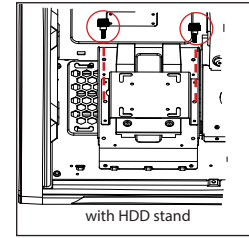
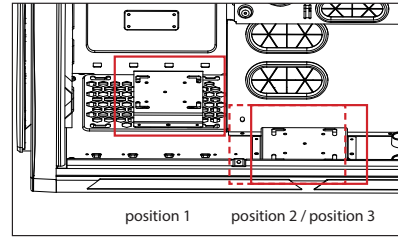
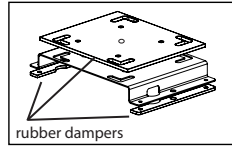
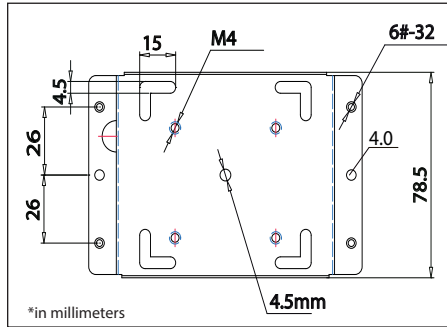

Pump bracket with universal mounting allows for multiple pumps to be installed.

Support de pompe avec montage universel permettant d'installer plusieurs pompes.

Pumpenhalterung mit Universalmontage ermöglicht die Installation mehrerer Pumpen.

La staffa della pompa con collegamento universale permette di installare varie pompe.

Suporte da Bomba com suporte universal permite que múltiplas bombas sejam instaladas.

El soporte de bomba con montaje universal le permite instalar varias bombas.

Pompbeugel met universele schroefgaten geeft ondersteuning voor meerdere type pompen.

Pump bracket can be put on the HDD stand or without.

Le support pompe peut être mis sur la cage de DD ou sans une.

Die Pumpenhalterung kann am Festplattenkäfig befestigt oder ohne diesen montiert werden.

La staffa della pompa può essere installata con o senza cage HDD.

Suporte da bomba pode ser colocado no berço do HDD ou sem.

El soporte de bomba se puede colocar en el compartimento de la unidad de disco duro o sin él.

Pomp beugel kan op de HDD kooi voetstuk worden geplaatst of zonder de voetstuk.

15. WATERCOOLING INSTALLATION

RESERVOIR BRACKET

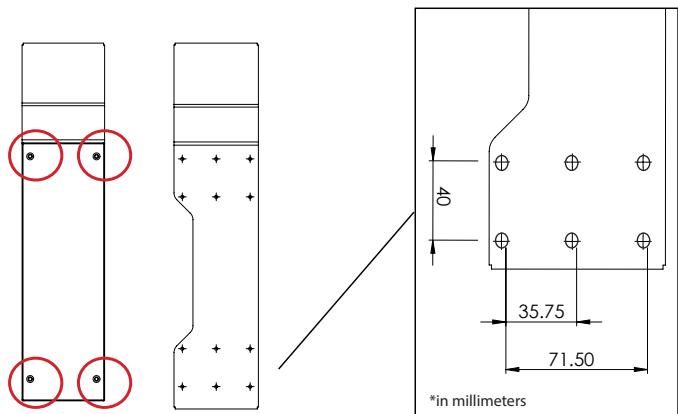

Unscrew the cover to install the reservoir

Dévissez le couvercle pour installer le réservoir

Lösen Sie die Abdeckung zum Installieren des Reservoirs

Svitare il coperchio per installare il serbatoio

Desparafuse a tampa para instalar o reservatório

Desatómille la cubierta para instalar el depósito

Schroef de deskel los om de reservoir te installeren

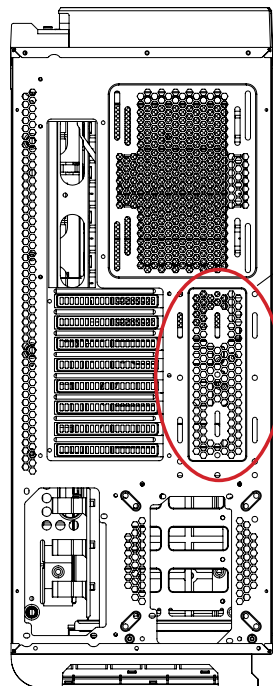

REAR VIEW

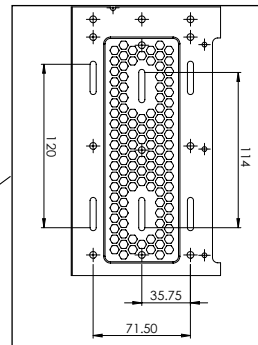

Reservoir rear mounting

Montage du réservoir à l'arrière

Rückseitige Reservoir-Montage

Installazione posteriore del serbatoio

Montagem traseira do reservatório

Montaje del depósito trasero

Reservoir achterzijde montage

16. SERVICES AND SUPPORT

If you have any questions or concerns, please visit Phanteks' website for technical support. We consider customer support, satisfaction and feedback an essential element of our overall marketing effort. Please feel free to contact our support team. Thank you!

Contact Us at:
www.phanteks.com
www.phanteksusa.com
www.phanteks.cn

For Warranty Information, please visit Phanteks' website.



Unleash unlimited possibilities

ENTHOO PRIMO
ENTHOO SERIES

PHANTEKS
DESIGNED IN THE NETHERLANDS