

## SRP Racing Pedals

Load Cell for the Best Control

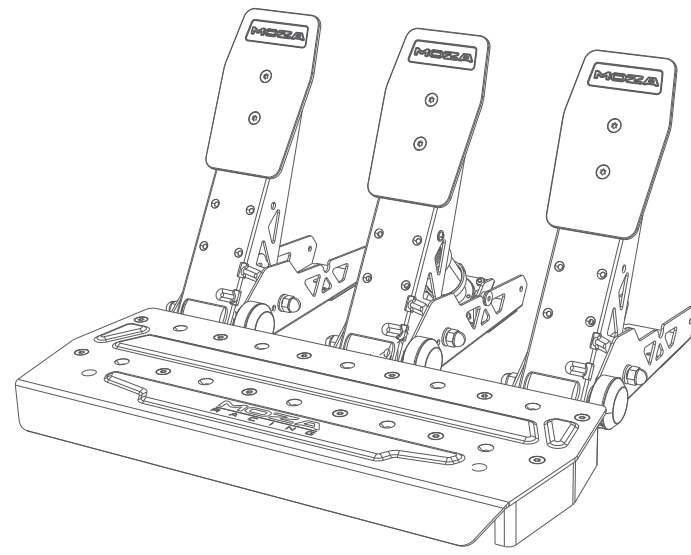

User manual 使用说明书

### 01 Product Description

- Made of high-strength steel
- High precision pressure sensor for up to 75 KG
- 16-bit high precision angle sensor
- Braking pressure sensor and angle sensor fusion algorithm
- Braking spring and damping block combined
- Adjustable pedal spacing
- Detachable pedal design
- Compatible with floor and professional cockpit
- Pedal travel software adjustment brackets

### 02 Pedal Installment

- Place the pedals on the footrest, use a 2.5mm hexagon wrench to fix the M4\*10 screws to the footrest. It is recommended that all 4 screws of each pedal are tightened to ensure stability.
- Connect the wires to the corresponding ports (the connecting wire of the clutch angle sensor needs to pass through the middle of the brake base, otherwise it may press on the wire harness after installing the pedal) and use the wire under the pedal base to clamp the wire harness to prevent the wiring harness is worn or tangled during intense driving.

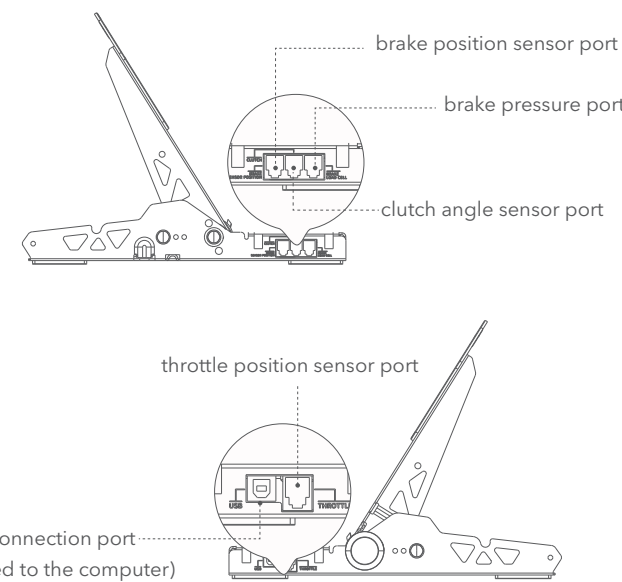

- You will see the status of the SRP pedal in the Pit House once the wires are connected and the USB cable is plugged into the computer. (If it remains gray or does not respond, please unplug the USB port on the PC, turn off the MOZA Pit House, reconnect the USB port and turn on the MOZA Pit House)
- You could check the working status of the pedal, reset the pedal starting point, ending point, and pedal travel in the MOZA Pit House.

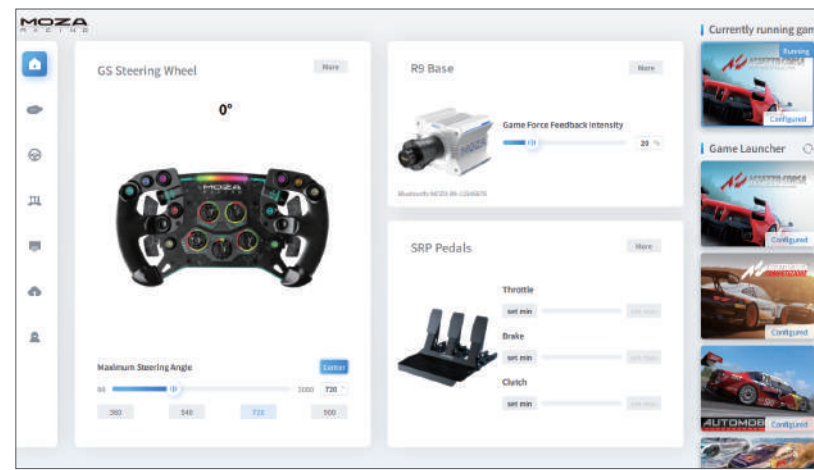

### 03 How to adjust the pedal spacing

Move left and right to adjust the spacing between the pedals and the base holes, select the screw hole and then tighten the screw. (The accelerator, brake and clutch are adjusted in the same way)

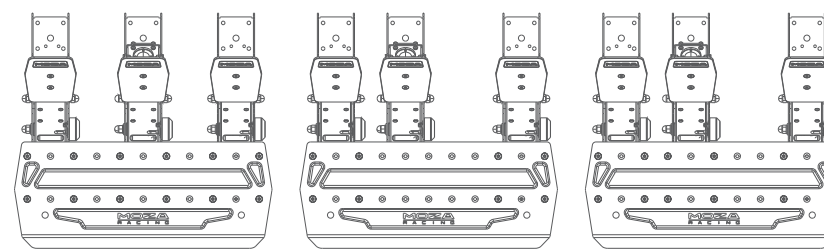

### 04 Instructions for adjusting the pedal board height

Use a 2.5mm hexagon wrench to turn the screws on the board surface of the pedal counterclockwise and use a 7mm open-end wrench to remove the nuts on the back and the screws on the board, move the board up and down to adjust the height of the board according to your needs, and then fasten the nuts and screws to the board surface. (The accelerator, brake and clutch are adjusted in the same way)

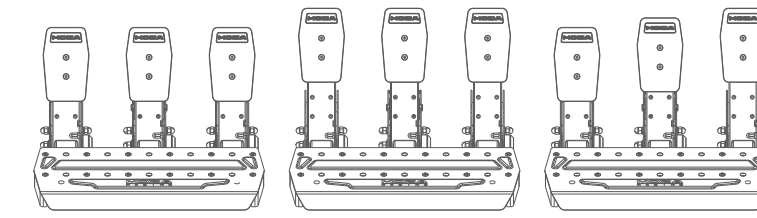

### 05 Packing Details

- SRP pedal
- Tool kit:
  - M4\*10 socket head countersunk head x12
  - M8\*12 hexagon socket head screw x3
  - M6\*20 socket head cap screws x2
  - 2.5mm hexagon wrench x1
  - 7mm open end wrench x1
  - 5mm hexagon wrench x1
- Type A to Type B USB cable

### 06 Product Parameters

Material: high-strength steel  
 Color: black  
 Brake sensing method: pressure sensor and angle sensor fusion algorithm  
 Pressure sensor maximum range: 75kg  
 Angle sensor resolution: 16 bits  
 Brake structure: spring + damping block  
 Throttle sensing method: angle sensor  
 Clutch sensing method: angle sensor  
 Pedal spacing: adjustable  
 Pedal surface height: adjustable  
 Pedal connection port: USB  
 Pedal travel software adjustment: yes  
 Pedal travel reverse function: yes

正面

### 01 产品介绍

- 高强度打造
- 75KG高精度压力传感器
- 16位高精度角度传感器
- 刹车压力传感器和角度传感器融合算法
- 刹车弹簧与阻尼块黄金组合
- 踏板间距可调节
- 踏板可拆卸式设计
- 兼容放地面和专业支架
- 踏板行程软件调节

### 02 踏板安装流程

- 将踏板装在搁脚板上并调整好安装孔位,使用2.5mm六角扳手将M4\*10螺丝固定到搁脚板上,为了保证使用稳定性,建议每个踏板的全部4颗螺丝都安装牢固。
- 将连接线连接到对应的安装接口处(离合压力传感器连接线需从刹车底座中间处穿过,否则安装完踏板后可能会压到线束),利用踏板底座下的线卡卡住线束,以防止激烈驾驶时线束磨损及缠绕。

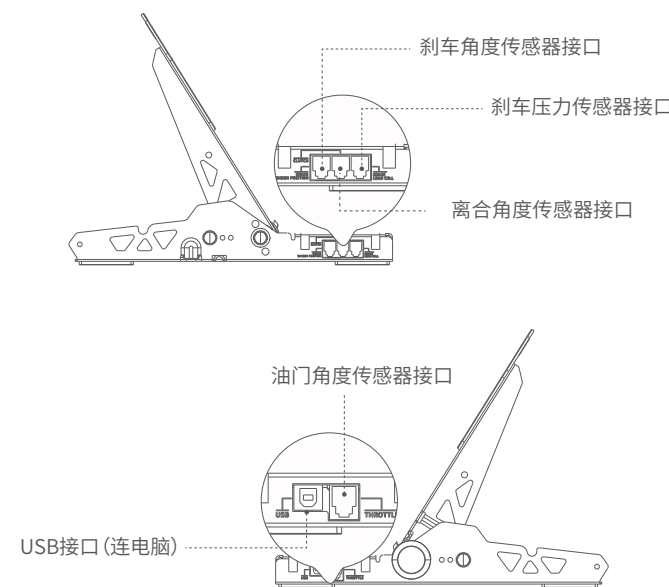

- 线束连接正确并将USB线插入电脑后,在MOZA Pit House中即可看到SRP踏板的工作状态。(若设备仍为灰色或踩踏后无响应,请拔出PC端USB接口,关闭MOZA Pit House,再重新接入USB接口并打开MOZA Pit House)
- 可在MOZA Pit House中查看踏板的工作状态,重新设置踏板的起点、终点和行程。

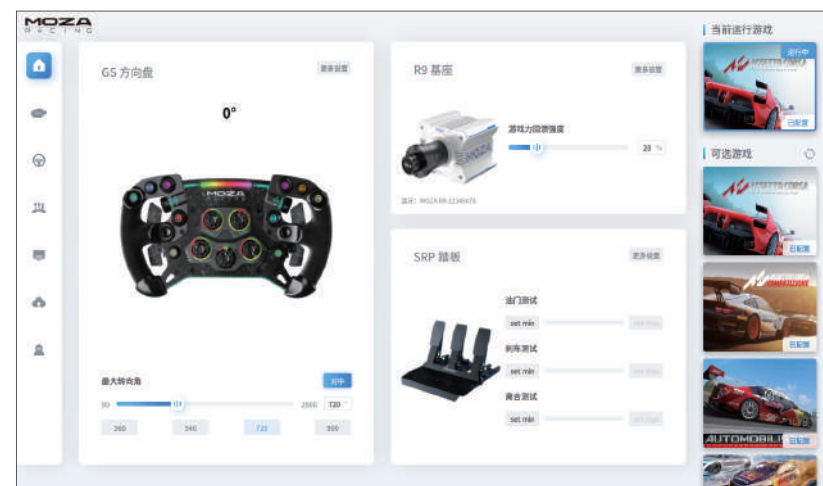

### 03 踏板间距调节方法

左右移动调节踏板与底座孔位之间的间距,选择好螺丝孔位后再锁紧螺丝,(油门、刹车和离合的间距调节方式一致)

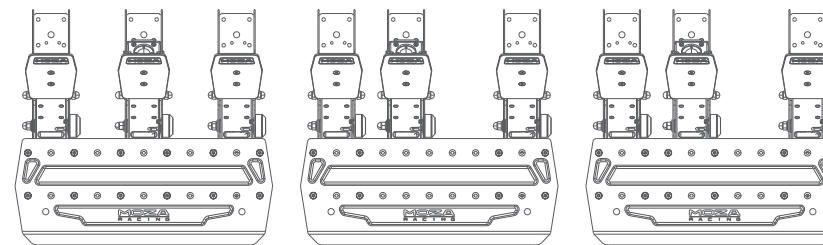

### 04 踏板板面高度调节说明

使用2.5mm六角扳手逆时针转动踏板板面的螺丝并配合使用7mm开口扳手卸下背面螺母与板面螺丝,上下移动板面根据自身需求调节板面高度,然后将螺母与螺丝拧至与板面贴合并固定(油门、刹车和离合的板面调节方式一致)

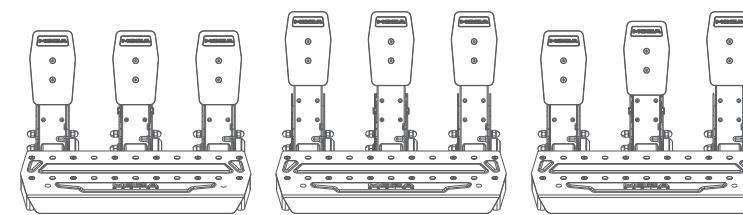

### 05 包装清单

- SRP踏板
- 工具包:
  - M4\*10内六角沉头螺丝x12
  - M8\*12内六角伞头螺丝x3
  - M6\*20内六角圆柱螺丝x2
  - 2.5mm六角扳手x1
  - 7mm开口扳手x1
  - 5mm六角扳手x1
- Type A 转 Type B USB线

### 06 产品参数

整体材质:高强度钢  
 颜色:黑色  
 刹车感应方式:压力感应+角度传感器融合算法  
 压力传感器最大量程:75kg  
 角度传感器分辨率:16位  
 刹车结构:弹簧+阻尼块  
 油门感应方式:角度传感器  
 离合感应方式:角度传感器  
 踏板间距:可调  
 踏板面高低:可调  
 踏板接口:USB直连  
 踏板行程软件调节:支持  
 踏板行程反转功能:支持

背面

### 产品保修卡

产品型号	购买日期
用户姓名	用户电话
产品条码	通讯地址

经销商信息(盖章)

### 产品保修条例

#### 保修期

自购机日起,底座主体,方向盘,踏板和仪表显示屏保修12个月。设备外壳、说明书、线材、螺丝、扳手、包装等不在“一年免费保修服务”范围内,但您可以选择有偿服务。购买者在以下条件下不享受免费保修服务:

- 超过三包有效期的;
  - 无三包凭证及有效发票的,但能够证明该产品在三包有效期内的除外;
  - 保修凭证上的型号与维修产品型号不符或者涂改的;
  - 非本公司特约维修人员拆卸造成损坏的;
  - 因不可抗力造成损坏的;
  - 未按产品使用说明书要求使用、维护、保养而造成损坏的;
- 保修期限鉴于产品部位、不同国家法律法规等差异,将有所不同。相关国家与区域的保修期限,请咨询MOZA官方或购买时联系的MOZA授权经销商。



尺寸:126\*180mm

材质:80G书写纸